

# STS320™

## PRODUCT REFERENCE GUIDE

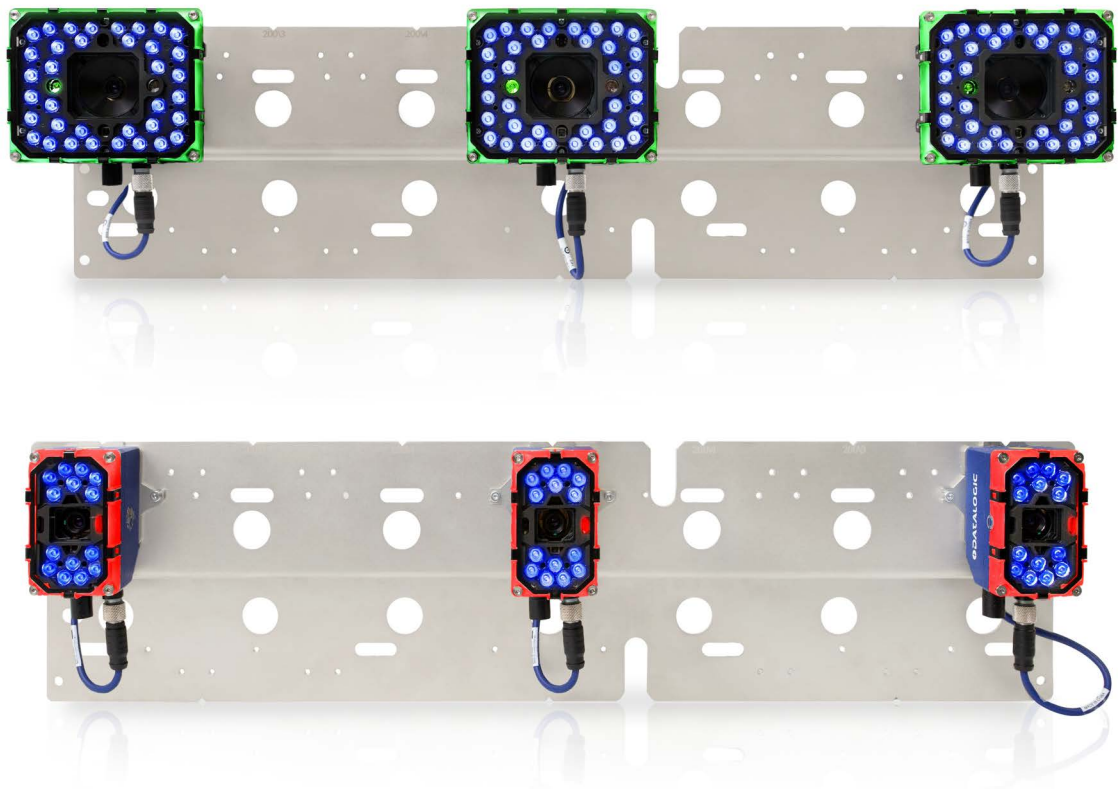

Solution for Tire Sorting

 **DATALOGIC**

**Datalogic S.r.l.**

Via S. Vitalino, 13  
40012 Calderara di Reno (BO)  
Italy  
Tel. +39 051 3147011  
Fax +39 051 3147205

**© 2021-2023 Datalogic S.p.A. and /or its affiliates**

All rights reserved. Without limiting the rights under copyright, no part of this documentation may be reproduced, stored in or introduced into a retrieval system, or transmitted in any form or by any means, or for any purpose, without the express written permission of Datalogic S.p.A. and/or its affiliates.

Owners of Datalogic products are hereby granted a non-exclusive, revocable license to reproduce and transmit this documentation for the purchaser's own internal business purposes. Purchaser shall not remove or alter any proprietary notices, including copyright notices, contained in this documentation and shall ensure that all notices appear on any reproductions of the documentation.

Electronic versions of this document may be downloaded from the Datalogic website ([www.datalogic.com](http://www.datalogic.com)). If you visit our website and would like to make comments or suggestions about this or other Datalogic publications, please let us know via the "Contact" page.

**Disclaimer**

Datalogic has taken reasonable measures to provide information in this manual that is complete and accurate, however, Datalogic shall not be liable for technical or editorial errors or omissions contained herein, nor for incidental or consequential damages resulting from the use of this material. Datalogic reserves the right to change any specification at any time without prior notice.

**Trademarks**

Datalogic and the Datalogic logo are registered trademarks of Datalogic S.p.A. in many countries, including the U.S.A. and the E.U.

STS320, ID-NET, DL.CODE and X-PRESS are trademarks of Datalogic S.p.A. and/or its affiliates. All other trademarks and brands are property of their respective owners.

**Patents**

See [www.patents.datalogic.com](http://www.patents.datalogic.com) for patent list.

# CONTENTS

---

<b>PREFACE</b> .....	<b>V</b>
<b>About this Manual</b> .....	<b>v</b>
Manual Conventions .....	v
<b>Technical Support</b> .....	<b>v</b>
Support Through the Website .....	v
Reseller Technical Support .....	vi
.....	vi
<b>COMPLIANCE</b> .....	<b>VII</b>
<b>General</b> .....	<b>vii</b>
<b>Power Supply</b> .....	<b>vii</b>
<b>EMC Compliance</b> .....	<b>vii</b>
<b>CE Compliance</b> .....	<b>vii</b>
<b>Laser Safety</b> .....	<b>viii</b>
<b>LED Safety</b> .....	<b>viii</b>
<b>HANDLING</b> .....	<b>IX</b>
<b>GENERAL VIEW</b> .....	<b>X</b>
<b>INTRODUCTION</b> .....	<b>1</b>
<b>STS320 - Solution for Tire Sorting</b> .....	<b>1</b>
<b>Terminology</b> .....	<b>2</b>
Code Resolution .....	2
DOF .....	2
FOV .....	2
<b>STS320 Feasibility Requirements</b> .....	<b>3</b>
Highest Application Code Resolution .....	3
Maximum Application DOF .....	3
Conveyor Operating Width .....	4
Maximum Application FOV .....	5
Maximum Conveyor Speed .....	5
Extracting Tire Size from Tire Sidewall Markings .....	6
<b>STS320 Model Descriptions</b> .....	<b>7</b>
<b>Power Requirements</b> .....	<b>8</b>
<b>STS320 Accessories</b> .....	<b>9</b>
<b>INSTALLATION</b> .....	<b>10</b>
<b>STS320 Supporting Frame</b> .....	<b>10</b>
Frame Width .....	11
Frame Length .....	12
Mounting Distance .....	13
Frame Bill Of Materials .....	15
<b>Mechanical Dimensions</b> .....	<b>16</b>
<b>STS320 Main Plate Mounting</b> .....	<b>23</b>
STS320 Plate Support Assembly Positioning .....	25
<b>Presence Sensor Positioning</b> .....	<b>26</b>
<b>Matrix 320 ATS</b> .....	<b>28</b>
Matrix 320 ATS as Replacement Reader .....	28
Matrix 320 ATS as Stand Alone Reader .....	28
Matrix 320 ATS Mounting Distance .....	29

<b>ELECTRICAL CONNECTIONS</b> .....	<b>30</b>
<b>STS320 Wiring Diagram</b> .....	<b>30</b>
<b>Power Supply</b> .....	<b>31</b>
<b>M12 X-Coded 8-Pin Connector (Ethernet)</b> .....	<b>31</b>
<b>Digital Inputs</b> .....	<b>32</b>
Input Connections for Presence Sensors (provided in the package) .....	33
Input Connections from PLC .....	34
<b>Digital Outputs</b> .....	<b>35</b>
Output Connections Using STS320 Power .....	36
<b>DISPLAY MENUS</b> .....	<b>37</b>
<b>Main Menu</b> .....	<b>38</b>
<b>View Menus</b> .....	<b>39</b>
Standard .....	39
Network State .....	39
<b>Extended Menu</b> .....	<b>39</b>
<b>SOFTWARE CONFIGURATION</b> .....	<b>40</b>
<b>STS320 Default Configuration</b> .....	<b>40</b>
<b>Configuration using Web Discovery</b> .....	<b>40</b>
<b>Backup Procedure using CBX500 HMI Interface</b> .....	<b>42</b>
Keypad and Display .....	42
Backup procedure .....	42
<b>Web Monitor</b> .....	<b>43</b>
Info page .....	43
Monitoring Page .....	43
Statistics Page .....	44
Diagnostics Page .....	45
Web Mosaic .....	45
<b>Configuration using DL.CODE</b> .....	<b>47</b>
Quick Start .....	47
Ethernet Device Discovery .....	48
Device Configuration .....	48
Backup and Restore Through DL.CODE .....	49
Backup .....	50
Restore .....	50
Replacement .....	50
Unreadable Codes Management .....	51
<b>MAINTENANCE</b> .....	<b>53</b>
<b>STS320: What You Can and Cannot Do</b> .....	<b>53</b>
<b>Cleaning</b> .....	<b>53</b>
<b>TROUBLESHOOTING</b> .....	<b>54</b>
<b>General Guidelines</b> .....	<b>54</b>
<b>TECHNICAL FEATURES</b> .....	<b>56</b>

# PREFACE

---

## ABOUT THIS MANUAL

This Product Reference Guide is provided for users seeking advanced technical information, including connection, programming, maintenance and specifications. The Installation Guide and other publications associated with this product can be downloaded free of charge from the website listed on the back cover of this manual.

## Manual Conventions

The following conventions are used in this document:

The symbols listed below are used in this manual to notify the reader of key issues or procedures that must be observed when using the reader:



**NOTE**

**Notes contain information necessary for properly diagnosing, repairing and operating the reader.**



**CAUTION**

**The CAUTION symbol advises you of actions that could damage equipment or property.**



**WARNING**

**The WARNING symbol advises you of actions that could result in harm or injury to the person performing the task.**

## TECHNICAL SUPPORT

### Support Through the Website

Datalogic provides several services as well as technical support through its website. Log on to ([www.datalogic.com](http://www.datalogic.com)).

For quick access, from the home page click on the search icon , and type in the name of the product you're looking for. This allows you access to download Data Sheets, Manuals, Software & Utilities, and Drawings.

Hover over the Support & Service menu for access to Services and Technical Support.

## Reseller Technical Support

An excellent source for technical assistance and information is an authorized Datalogic reseller. A reseller is acquainted with specific types of businesses, application software, and computer systems and can provide individualized assistance.

# COMPLIANCE

---

## GENERAL

For installation, use and maintenance it is not necessary to open the reader.

Only connect Ethernet and dataport connections to a network which has routing only within the plant or building and no routing outside the plant or building.

## POWER SUPPLY

ATTENTION: READ THIS INFORMATION BEFORE INSTALLING THE PRODUCT

The unit is intended to be powered by an external power supply ES1, PS3 according to IEC 62368-1:2014.

## EMC COMPLIANCE

In order to meet the EMC requirements:

- connect reader chassis to the plant earth ground by means of a flat copper braid shorter than 100 mm;
- for CBX connections, connect pin “Earth” to a good Earth Ground;
- for direct connections, connect your cable shield to the locking ring nut of the connector.

## CE COMPLIANCE

CE marking states the compliance of the product with essential requirements listed in the applicable European directive. Since the directives and applicable standards are subject to continuous updates, and since Datalogic promptly adopts these updates, therefore the EU declaration of conformity is a living document. The EU declaration of conformity is available for competent authorities and customers through Datalogic commercial reference contacts. Since April 20th, 2016 the main European directives applicable to Datalogic products require inclusion of an adequate analysis and assessment of the risk(s). This evaluation was carried out in relation to the applicable points of the standards listed in the Declaration of Conformity. Datalogic products are mainly designed for integration purposes into more complex systems. For this reason it is under the responsibility of the system integrator to do a new risk assessment regarding the final installation.

**Warning:** This is a Class A product. In a domestic environment this product may cause radio interference in which case the user may be required to take adequate measures.

# LASER SAFETY

This product conforms to the applicable requirements of IEC 60825-1 and complies with 21 CFR 1040.10 except for deviations pursuant to Laser Notice N° 56, date May 8, 2019. This product is classified as a Class 2 laser product according to IEC 60825-1 regulations.



**Use of controls or adjustments or performance of procedures other than those specified herein may result in exposure to hazardous visible laser light.**

Disconnect the power supply when opening the device during maintenance or installation to avoid exposure to hazardous laser light. The laser beam can be switched on or off through a software command.

The following warning label content is applied to the laser equipped products indicated in the General View illustration of this document.



Example Laser Warning Labels

The package includes labels for countries where the warning text in other languages is mandatory. Put them on the product instead of the English version.



To be applied on each Matrix 320 ATS-xxx

To be applied on the mounting bracket

# LED SAFETY

For all Datalogic STS320 compatible internal illuminators, LED emission is classified into Risk Group 1 according to EN 62471:2010.



# HANDLING

The STS320 is designed to be used in an industrial environment and is built to withstand vibration and shock when correctly installed, however it is also a precision product and therefore before and during installation it must be handled correctly to avoid damage.

- avoid that the array is dropped
- do not fine tune the positioning by striking the array

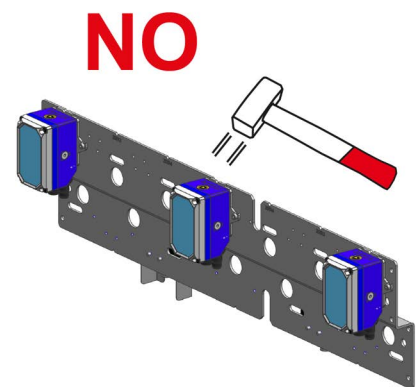
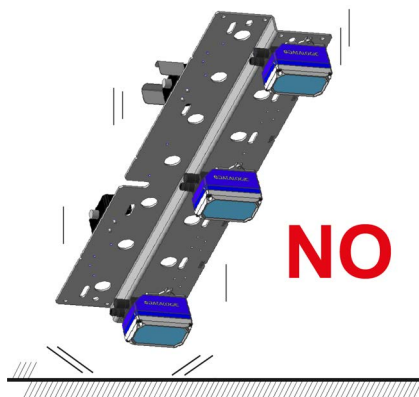

- do not weld the array into position, which can cause electrostatic, heat or reading window damage.
- do not spray paint near the array, which can cause reading window damage.

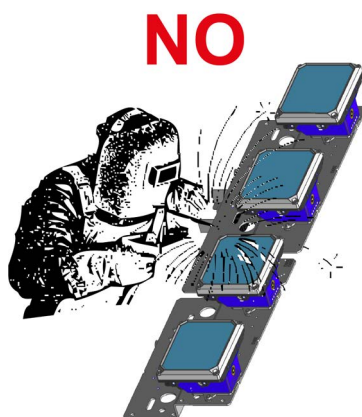

# GENERAL VIEW

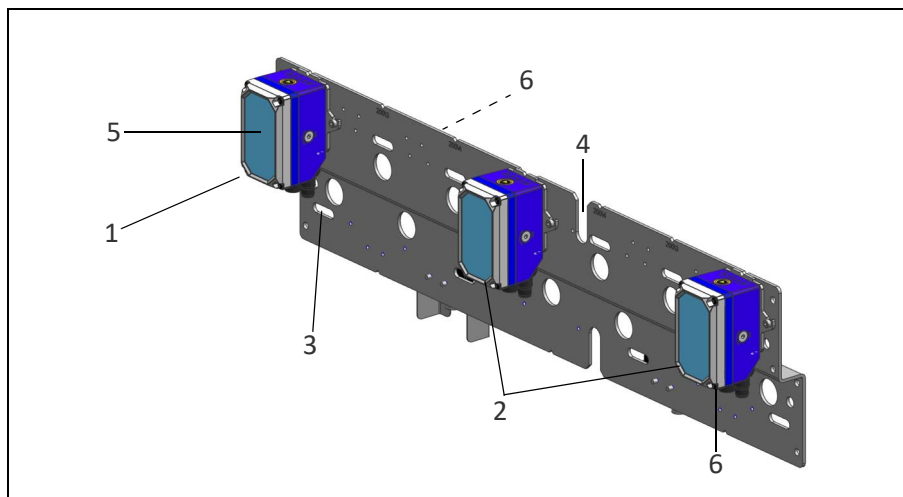

Figure 1- STS320 (14 LEDs illuminator)

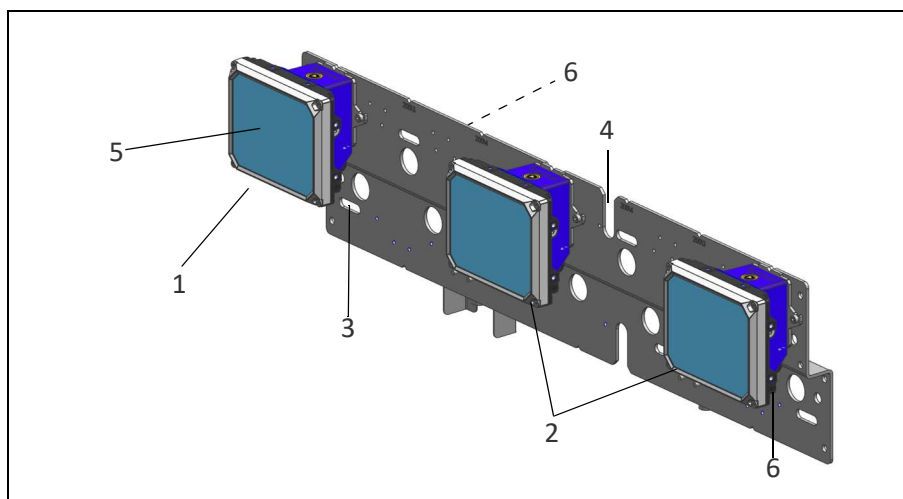

Figure 2 - STS320 (36 LEDs illuminator)

1. ID-NET™ Master	4. Positioning Slot
2. ID-NET™ Slaves	5. Reading Windows
3. Mounting Slots	6. Laser Class and Warning Labels

# CHAPTER 1

## INTRODUCTION

---

### STS320 - SOLUTION FOR TIRE SORTING

STS320, which means **S**olution for **T**ire **S**orting, is a solution designed to be easily integrated into a sorting system for reading barcodes on the tires.

The solution, made up of an array of Matrix 320™ ATS readers has been studied to be a pre-mounted, pre-configured system entirely validated at the factory, in order to be quickly and easily installed by any technician.

The STS320 provides easy maintenance with a smart solution for fast replacement of any single Matrix 320™ ATS reader.

There are a number of STS320 models that can be chosen to meet all customer needs in terms of maximum code resolution, conveyor width and depth of field.

- Multiple Matrix 320™ ATS readers are combined in an array designed to cover a fixed conveyor or belt width at a fixed range of distances.
- The readers are part of a Master/Slave high speed ID-NET™ network.
- The Master collects the data from the Slaves, handles I/O and communicates with the host.
- All external connections take place through the CBX500 connection box.
- Two photoelectronic sensors are included for triggering the reading phase. Alternatively, the reading phase can be controlled by Host commands from the serial, Ethernet IP or Fieldbus interfaces.

# TERMINOLOGY

This manual will refer to some technical terms when explaining how to choose and install the STS320. The following list includes the most used terms.

## Code Resolution

Code Resolution is the width of the narrowest module (element) in a barcode, usually expressed in millimeters. It is also commonly expressed in mils (thousandths of an inch).

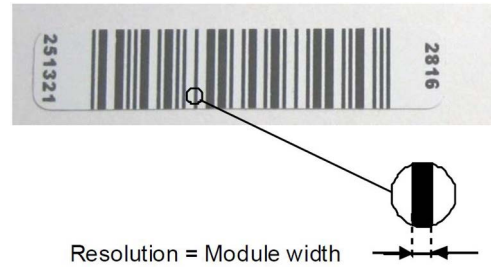

## DOF

DOF stands for Depth Of Field. It indicates the range (distance from the reader) where the barcode can be read.

## FOV

FOV stands for Field Of View. It describes the reading area at a given reading distance within the DOF.

Horizontal FOV defines the reading width of the STS320 across the conveyor. Vertical FOV defines the reading length of the STS320 parallel to the conveyor.

The guaranteed reading volume is defined as:

$$FOV_{Hmin} \times FOV_{Vmin} \times DOF$$

on Code 128 codes from the Datalogic Test Chart.

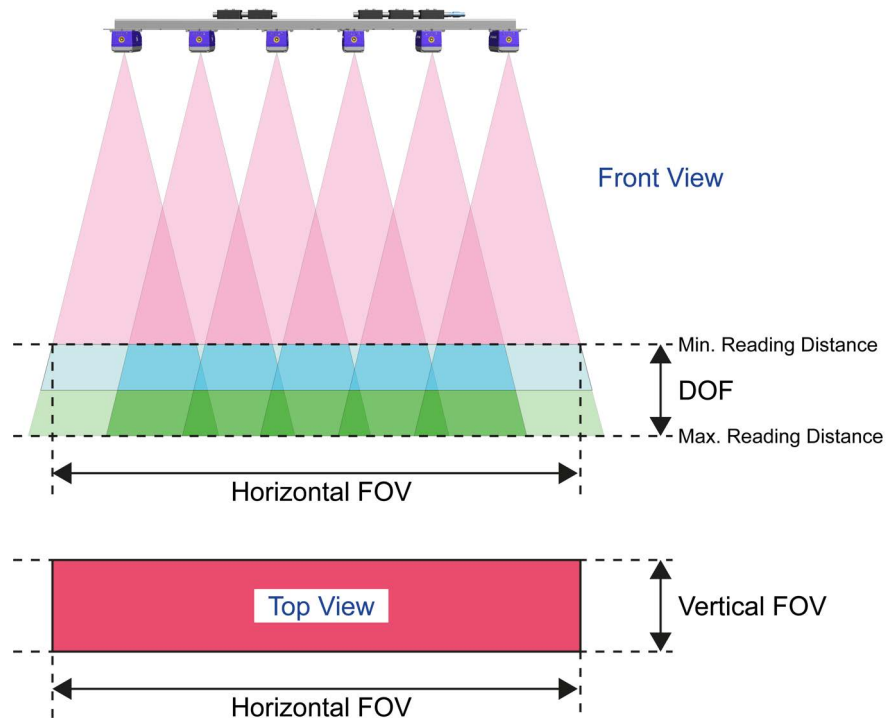

Tire Terminology	
<p><b>Width</b> It is the widest point from sidewall to sidewall of the tire.</p> <p><b>Height</b> It is the difference from the external to the internal diameter of the tire.</p> <p><b>Diameter</b> It is the internal diameter of the tire which will fit the car wheel rim.</p> <p><b>Bead</b> It is the part of the tire which contacts the car wheel rim. The barcode is usually applied here.</p>	

## STS320 FEASIBILITY REQUIREMENTS

In order to make the best STS320 solution choice that fits the application needs, some basic information is required.

### Highest Application Code Resolution

This data is fundamental for choosing the STS320 model. This information must be the minimum barcode module among all the barcodes to be read in the application.

STS320 is supplied for two nominal resolutions:

- **High Resolution**, 0.25 mm (10 mils)
- **Standard Resolution**, between 0.30 mm (12 mils) and 0.35 mm (14 mils)



**NOTE**

**If the resolution is higher than 0.25 mm (smaller module width), please contact your local Datalogic representative.**

### Maximum Application DOF

This data corresponds to the difference between the maximum width ( $W_{max}$ ) and the minimum width ( $W_{min}$ ) among all the tires to be sorted:

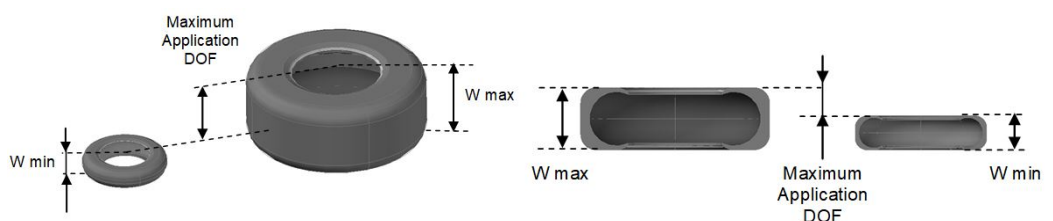

This information can be gathered by physically measuring the width of all tires to be sorted, and looking for the two limits.

Alternatively, you can collect the size information printed on all tires (refer to “Extracting Tire Size from Tire Sidewall Markings” on page 6).

STS320 satisfies different ranges of DOF according to the code resolution and reading station application type:

STS320 Model	Application Type	Nominal DOF mm (in)
STS320-003 STS320-004 STS320-013 STS320-014 STS320-015 STS320-016	Top Reading Passenger Car and Light Truck	250 (9.84)
STS320-103 STS320-104 STS320-113 STS320-114 STS320-115 STS320-116	Top Reading Commercial Vehicle	400 (15.75)
STS320-203 STS320-204 STS320-205	Near Reading and Bottom Reading Tires	170 (6.69)

### Conveyor Operating Width

This is the effective operative width where the tires can run:

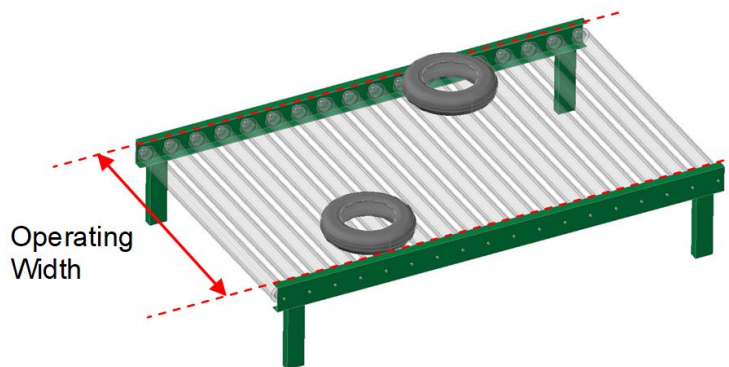

## Maximum Application FOV

This data is the maximum reading width where a barcode can be found by the STS320. Because the barcode is located on or next to the bead of the tire, the barcode will never be found at the edges of the Conveyor Operating Width. The Maximum Application FOV therefore can always be less than the Conveyor Operating Width:

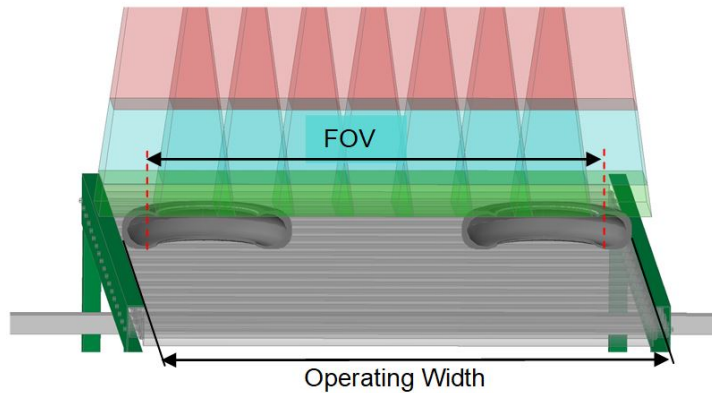

The figure above shows a sectional view of the tires to better understand the difference between the Maximum Application FOV and the Conveyor Operating Width.

the Maximum Application FOV can be calculated with the following formula:

$$\text{FOV} = \text{Operating Width} - 2 * (\text{Min. Tire Height} - \text{Barcode Position Margin})$$

## Maximum Conveyor Speed

The STS320 with factory default configuration can support speeds up to 1.5 m/s (295.27 fpm, 90 m/min).



**NOTE**

**Higher speeds can be obtained by modifying the configuration, please contact your local Datalogic representative for feasibility.**

## Extracting Tire Size from Tire Sidewall Markings

The best way to find out your tire size is to actually look at the tire sidewall. As you can see in the figure below, there is generally a lot of different information on the tire. However, for our purpose, we just need 3 pieces of information:

1. **Tire Width:** the “215” designation states the Width of the tire in millimeters at the widest point from sidewall to sidewall when mounted on the correct wheel.
2. **Tire Height:** the “65” designation is the Aspect Ratio. This ratio is calculated by dividing the section Height by the Width. Therefore, the tire height is calculated as:  

$$\text{Height} = \text{Ratio} * \text{Width} / 100$$
3. **Tire Diameter:** the “15” designation is the Diameter of the wheel rim in inches. This is the exact size that the tire will fit.

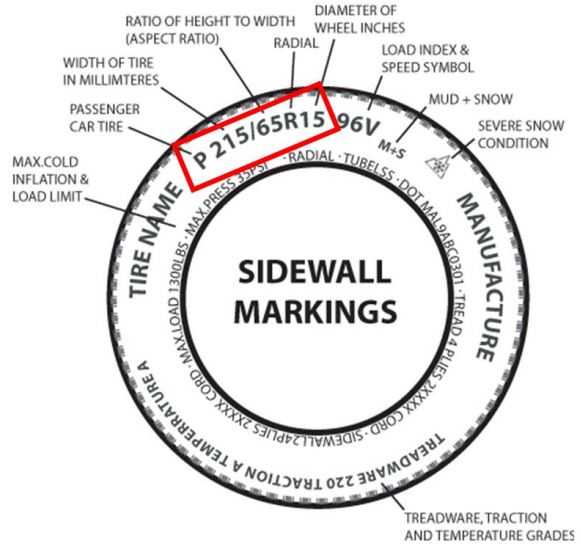

Once the whole list of the nominal values of all the tires has been collected, it is very easy to understand the application needs, and choose the correct STS320™ model. See the following tables:

	W [mm]	R [%]	D [in]	H [mm]	D <sub>int</sub> [mm]	D <sub>ext</sub> [mm]
Tire 1	120	70	12	84	304.8	472.8
Tire 2	175	65	14	114	355.6	583.1
Tire 3	185	55	14	102	355.6	559.1
Tire 4	205	60	15	123	381.0	627.0
Tire 5	205	65	15	133	381.0	647.5
Tire 6	190	50	17	95	431.8	621.8
Tire 7	100	100	18	100	457.2	657.2
Tire 8	275	45	18	124	457.2	704.7
Tire 9	275	45	20	124	508.0	755.5
Minimum [mm]	100.0			84.0		
Maximum [mm]	275.0			133.3	508.0	755.5
DOF Required [mm]	175.0					



**NOTE**

**D<sub>ext</sub> is the external tire diameter. Even if this is not used for the best choice of the STS320™, the above table shows it. It can be calculated as:**  

$$D_{ext} = D_{int} + (2 * H).$$



# STS320 MODEL DESCRIPTIONS

Once the main specifications have been collected, it is possible to choose the STS320 model which best fits the application according to the following rules:

- Highest Application Code Resolution  $\leq$  STS320 Nominal Code Resolution
- Maximum Application DOF  $\leq$  STS320 Nominal DOF
- Maximum Application FOV  $\leq$  STS320 Nominal Horizontal FOV

The models differ by Application Type, Code Resolution, and number of readers.

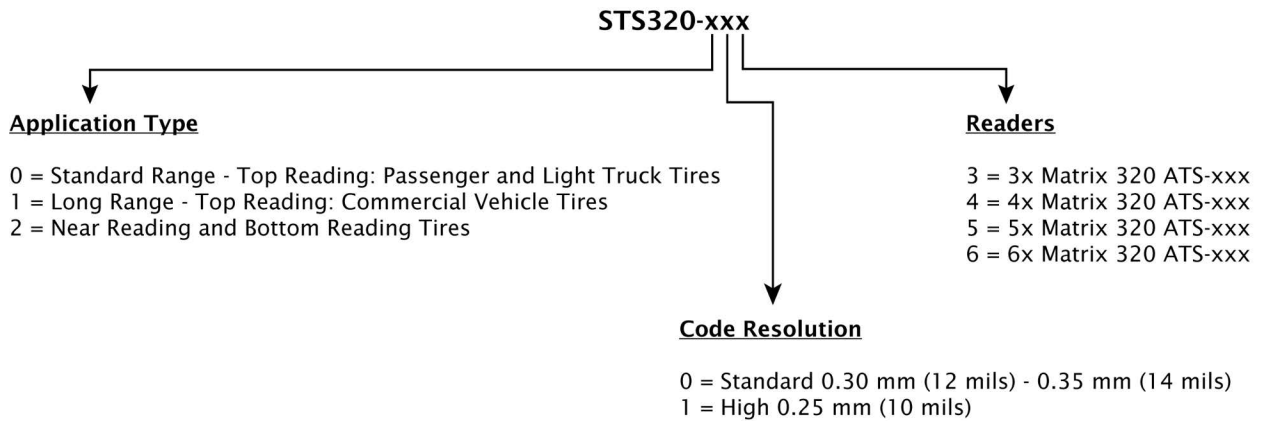

Single Matrix 320™ ATS-xxx models are used as stand alone readers having the same characteristics as the related application type STS320 models. They are also used as replacement readers for the relative STS320 stations.

The Reading Features of the various STS320 models are given in "[Mounting Distance](#)" on [page 13](#).

## POWER REQUIREMENTS

The STS320 solution kit doesn't include a power supply unit, which has to be ordered separately. The maximum power required depends on the model.

Power is supplied to the system through its connection box CBX500.

The following table indicates the compatible power supply to use according to the STS320 model. The supply current consumption values are given considering the default parameter settings with the array working at maximum throughput.

Model	Order No.	Peak Supply Current	Average Supply Current
<b>Top Reading Passenger Car and Light Truck Solution</b>			
STS320-003 TIRE SORT 3_HEAD ST RES	938100001	3.1 A max.	1.5 A
STS320-004 TIRE SORT 4_HEAD ST RES	938100002	4.1 A max.	1.9 A
STS320-005 TIRE SORT 5_HEAD ST RES	938100003	5.1 A max.	2.3 A
STS320-013 TIRE SORT 3_HEAD HI RES	938100004	3.1 A max.	1.5 A
STS320-014 TIRE SORT 4_HEAD HI RES	938100005	4.1 A max.	1.9 A
STS320-015 TIRE SORT 5_HEAD HI RES	938100006	5.1 A max.	2.3 A
STS320-016 TIRE SORT 6_HEAD HI RES	938100007	6.0 A max.	2.7 A
<b>Top Reading Commercial Vehicle Solution</b>			
STS320-103 TIRE SORT 3_HEAD ST RES LR	938100008	3.1 A max.	2.1 A
STS320-104 TIRE SORT 4_HEAD ST RES LR	938100009	4.1 A max.	2.7 A
STS320-113 TIRE SORT 3_HEAD HI RES LR	938100010	3.1 A max.	2.1 A
STS320-114 TIRE SORT 4_HEAD HI RES LR	938100011	4.1 A max.	2.7 A
STS320-115 TIRE SORT 5_HEAD HI RES LR	938100012	5.1 A max.	3.3 A
STS320-116 TIRE SORT 6_HEAD HI RES LR	938100013	6.0 A max.	3.9 A
<b>Near Reading and Bottom Reading Solution</b>			
STS320-203 TIRE SORT 3_HEAD ST RES NR	938100014	3.1 A max.	1.5 A
STS320-204 TIRE SORT 4_HEAD ST RES NR	938100015	4.1 A max.	1.9 A
STS320-205 TIRE SORT 5_HEAD ST RES NR	938100016	5.1 A max.	2.3 A



### NOTE

The suggested Power Supply for all models is PWR-240B (order no. 93ACC0264). For STS320-xx3 and STS320-xx4, we also suggest PWR-120 (order no. 93ACC0246).

## STS320 ACCESSORIES

Category	Description	Order No.
Power Supply	PWR-240 Power Unit 110/230VAC 24V 240W	93ACC0264
Cover	Cover LT 14L STS320/ATS320	93ACC0323
	Cover LT 36L STS320/ATS320	93ACC0324
Cables	M12-IP67 Cable To CBX or QL (1M)	93A050058
	M12-IP67 Cable To CBX or QL (3M)	93A050059
	M12-IP67 Cable To CBX or QL (5M)	93A050060
	M12-IP67 Cable To CBX or QL (10M)	93A051390
	M12-IP67 GIGA Ethernet Cable X-Coded (1M)	93A050122
	M12-IP67 GIGA Ethernet Cable X-Coded (3M)	93A050123
	M12-IP67 GIGA Ethernet Cable X-Coded (5M)	93A050124
Ethernet Switch	ETH GB Switch 8CH 24Vdc	93ACC1842
Software Management	WebSentinel Plus License Images 5 Arrays	93A100027
	WebSentinel Plus License Images 10 Arrays	93A100028
	WebSentinel Plus License Images 20 Arrays	93A100029
	WebSentinel Plus License Images 32 Arrays	93A100030
	WebSentinel Plus License Images 64 Arrays	93A100031

# CHAPTER 2

## INSTALLATION

---

### STS320 SUPPORTING FRAME

STS320 has been optimized to be mounted on aluminum profiles. A frame made up of aluminum profiles allows the easiest and fastest mounting, and in most cases is the best choice.

However, STS320 can also be mounted on different supports like a fixed column.

Because it is impossible to supply a standard frame that fits all the infinite needs of the customers, it must be designed during the feasibility study of the specific application.

When studying a frame, it is suggested to design it with some safe margins for adjustment because of unforeseen changes at installation time, e.g. obstacles or different height requirements. Even if the STS320 height can be calculated in advance, it is suggested to leave freedom on all three axes for fine adjustment in the field. The following figure shows how this can be achieved and represents the type recommended by Datalogic.

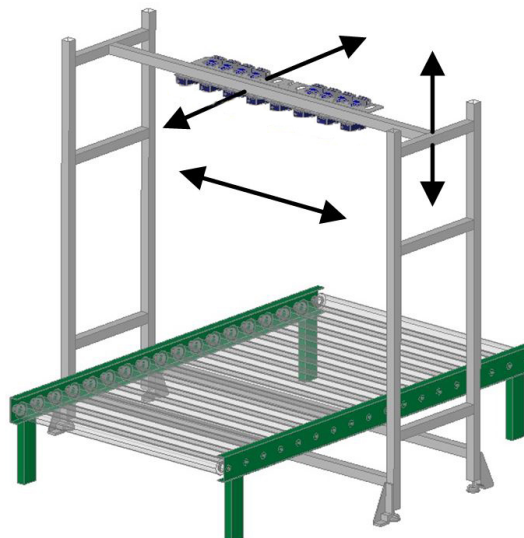

In this sample frame, the STS320 can be moved up-down, backward-forward, and left-right.

The length of the aluminum profiles has to be dimensioned according to the following constraints:

- physical conveyor width

- conveyor height from floor to the tire reading plane
- application DOF
- STS320 model
- minimum width ( $W_{\min}$ ) of the tires

The next three paragraphs suggest the formulas to be used for the frame dimensioning.

## Frame Width

The frame width has to be calculated according to the distances shown in the following figure:

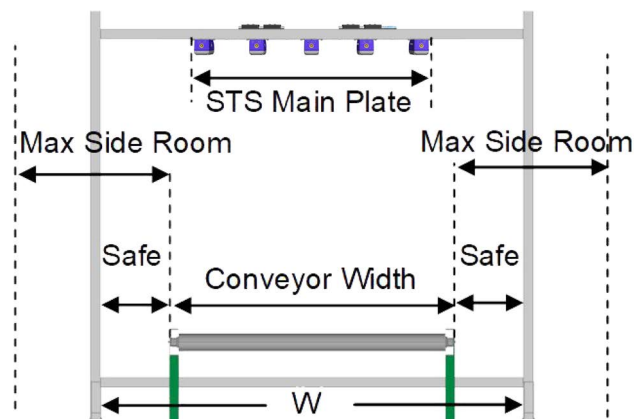

The **Safe** clearance between the frame and the conveyor sides has to be chosen according to the **Maximum Side Room** available. It is suggested to always keep at least 200 mm **Safe** clearance.

The length of the frame profiles  $W$  can be calculated in two ways, according to whether the STS320 main plate is wider than the **Conveyor Width**:

If Conveyor Width > STS main Plate:  $W = \text{Conveyor Width} + (2 * \text{Safe Margin})$

If Conveyor Width  $\leq$  STS main Plate:  $W = \text{STS Main Plate} + (2 * \text{Safe Margin})$

## Frame Length

It is suggested to keep at least 500 mm of **Safe** clearance for the frame Length (L). This allows good frame stability and freedom for moving both the reading phase sensor(s) and the STS320, forward or backward:

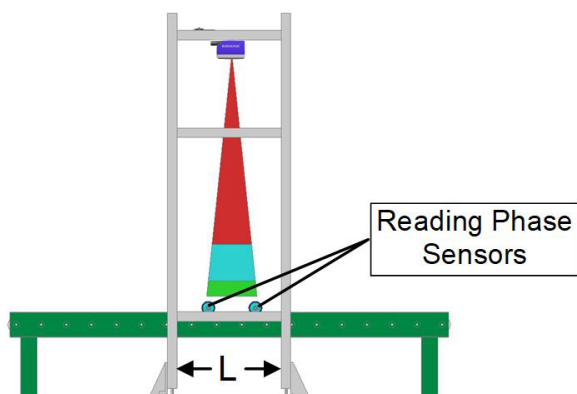

### NOTE

**There is not a specific calculation for (L).**

## Mounting Distance

Model	Readers	Code Resolution	Reading Width	DOF*	Min. Reading Distance	Max. Reading Distance	Focus Distance	Vertical FOV @ min. distance																																																								
	qty	mm (mils)	mm (in)	mm (in)	mm (in)	mm (in)	mm (in)	mm (in)																																																								
STS320-003	3	0.30 (12)	950 (37.4)	250 (9.84)	830 (32.68)	1080 (42.52)	940 (37.01)	202 (7.95)																																																								
STS320-004	4		1250 (49.21)						STS320-013	3	0.25 (10)	650 (25.59)	620 (24.41)	870 (34.25)	730 (28.74)	152 (5.98)	STS320-014	4	850 (33.46)	STS320-015	5	1050 (41.34)	STS320-016	6	1250 (49.21)	STS320-103	3	0.35 (14)	950 (37.4)	400 (15.75)	850 (33.46)	1250 (49.21)	1000 (39.37)	211 (8.31)	STS320-104	4	1250 (49.21)	STS320-113	3	0.25 (10)	650 (25.59)	830 (32.68)	1230 (48.43)	970 (38.19)	145 (5.71)	STS320-114	4	850 (33.46)	STS320-115	5	1050 (41.34)	STS320-116	6	1250 (49.21)	STS320-203	3	0.30 (12)	770 (30.31)	170 (6.69)	280 (11.02)	450 (17.72)	330 (12.99)	157 (6.18)	STS320-204
STS320-013	3	0.25 (10)	650 (25.59)		620 (24.41)	870 (34.25)	730 (28.74)	152 (5.98)																																																								
STS320-014	4		850 (33.46)																																																													
STS320-015	5		1050 (41.34)																																																													
STS320-016	6		1250 (49.21)																																																													
STS320-103	3	0.35 (14)	950 (37.4)	400 (15.75)	850 (33.46)	1250 (49.21)	1000 (39.37)	211 (8.31)																																																								
STS320-104	4		1250 (49.21)																																																													
STS320-113	3	0.25 (10)	650 (25.59)		830 (32.68)	1230 (48.43)	970 (38.19)	145 (5.71)																																																								
STS320-114	4		850 (33.46)																																																													
STS320-115	5		1050 (41.34)																																																													
STS320-116	6		1250 (49.21)																																																													
STS320-203	3	0.30 (12)	770 (30.31)	170 (6.69)	280 (11.02)	450 (17.72)	330 (12.99)	157 (6.18)																																																								
STS320-204	4		1010 (39.76)																																																													
STS320-205	5		1250 (49.21)																																																													

\* DOF = Max. Reading Distance - Min. Reading Distance

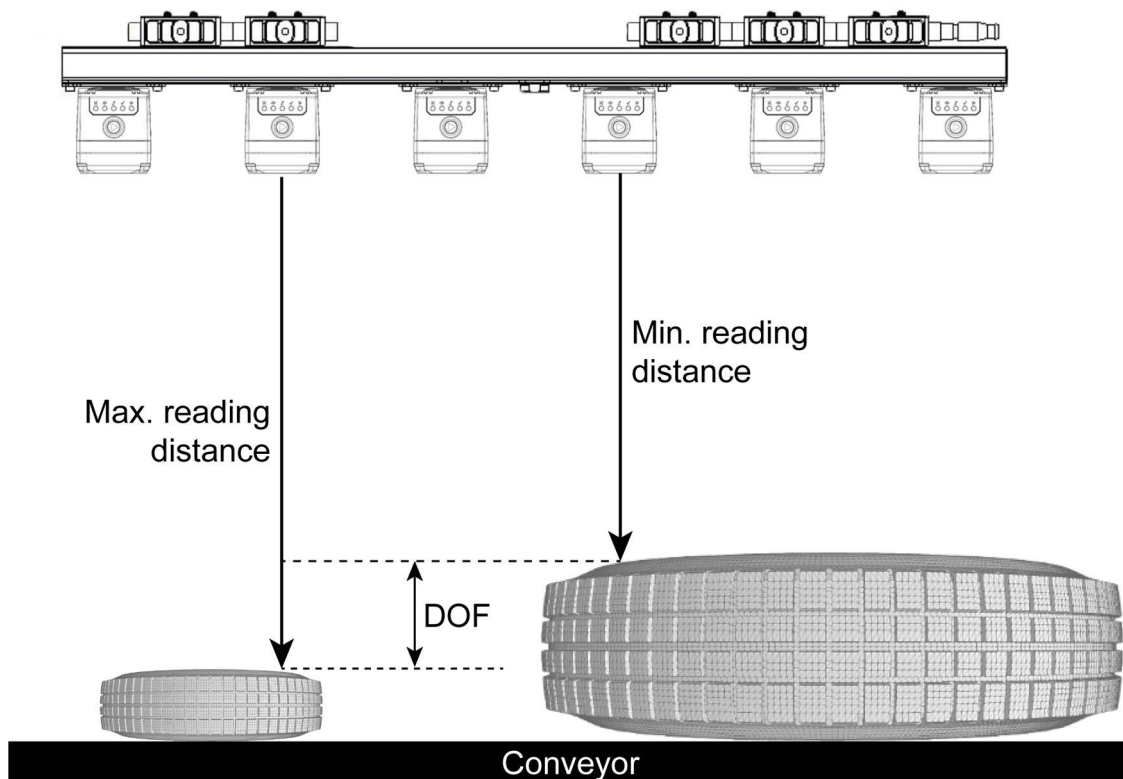

Figure 3 - STS320 (14 LEDs illuminators) mounting distance

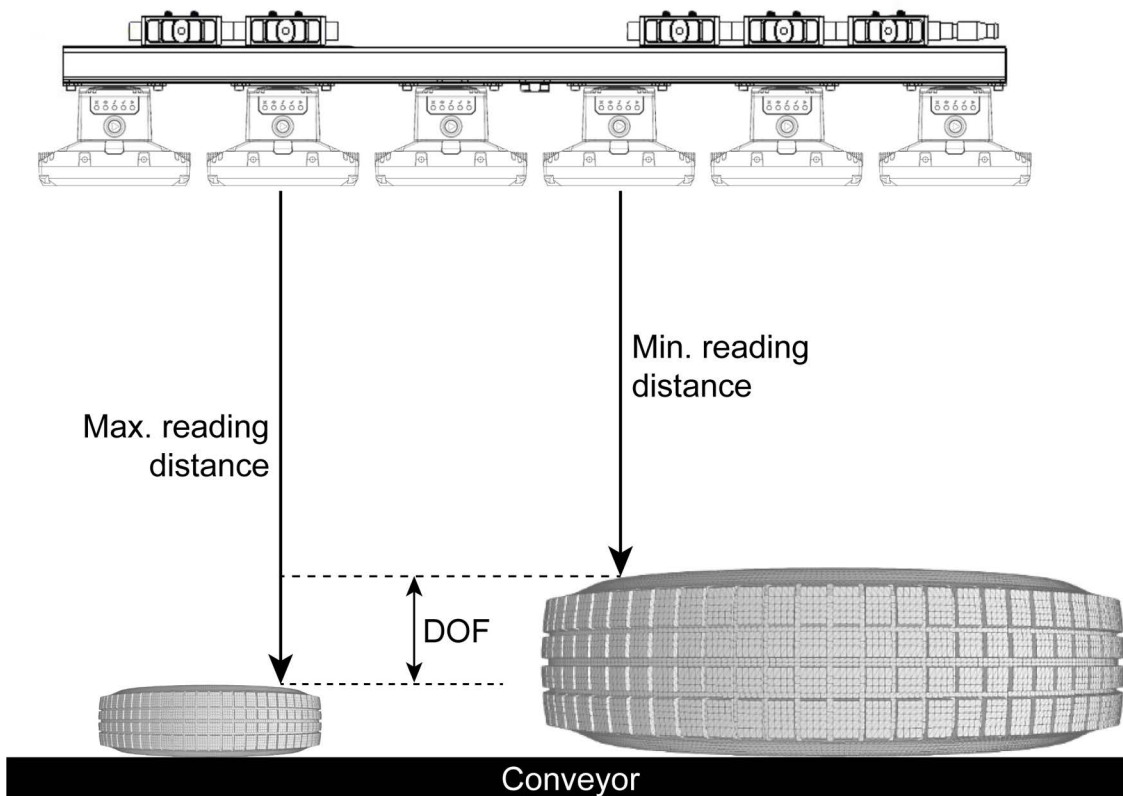

Figure 4 - STS320 (36 LEDs illuminators) mounting distance



## Frame Bill Of Materials

We suggest using Bosch aluminum profiles, although any other brand can fully satisfy this purpose.

The 45 x 45 mm profile section is the best compromise between frame stability and price.

The following bill of materials indicates a list of generic profiles: W, L and H.

Description	Quantity
Profile W	3
Profile L	6
Profile H	4
Angular brackets	20



### NOTE

**It is suggested to double the angular brackets on both ends of the profile supporting the STS320:**

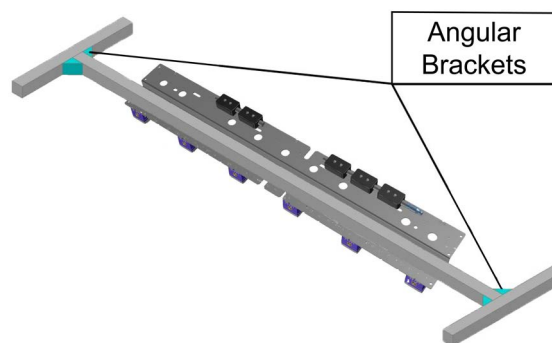

Once the frame has been fully mounted, the STS320 can be mechanically mounted.



## STS320-013

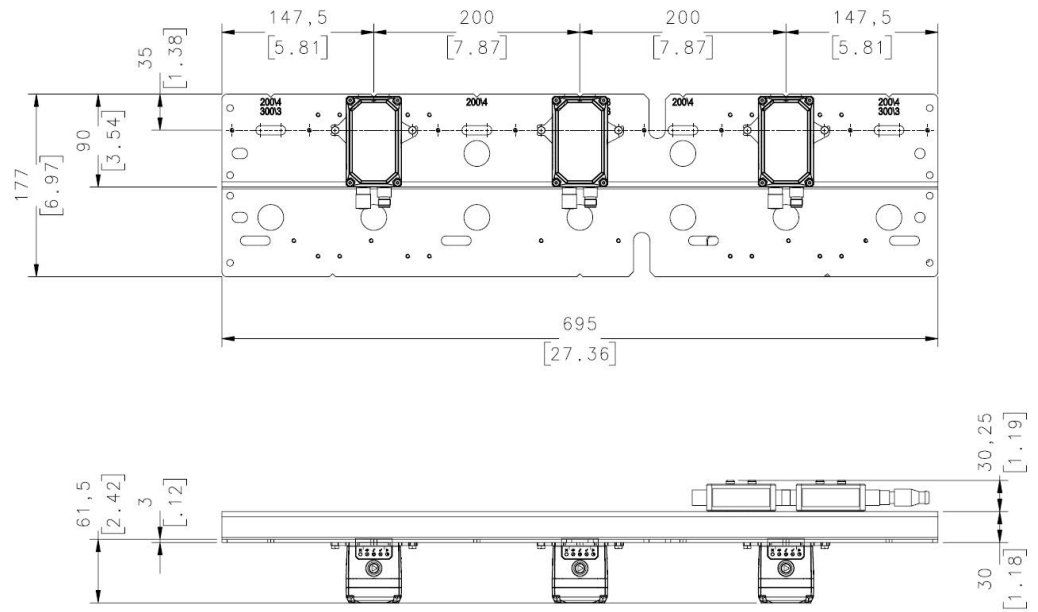

## STS320-014

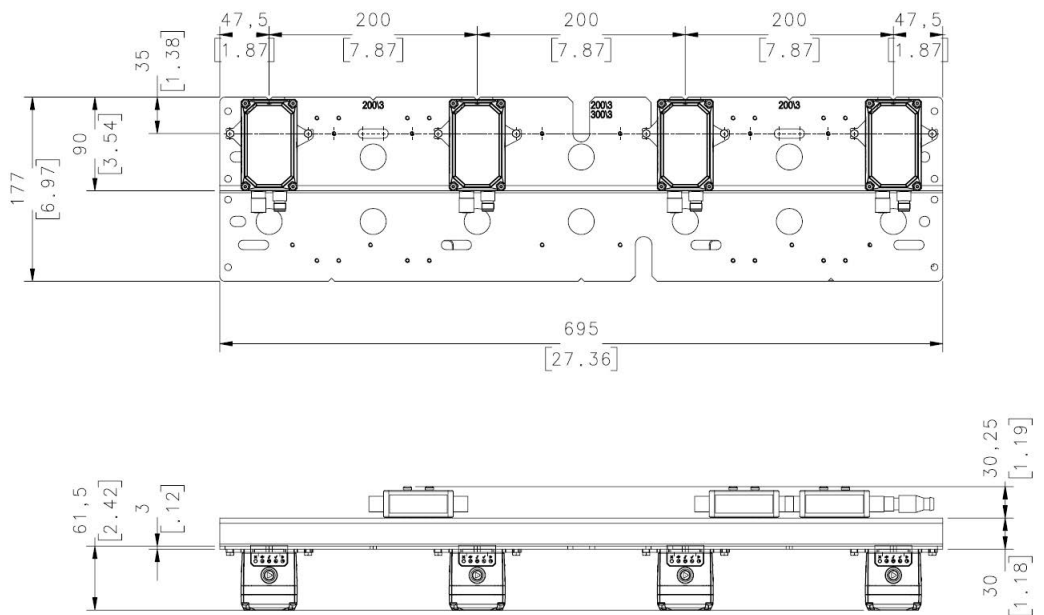

STS320-015

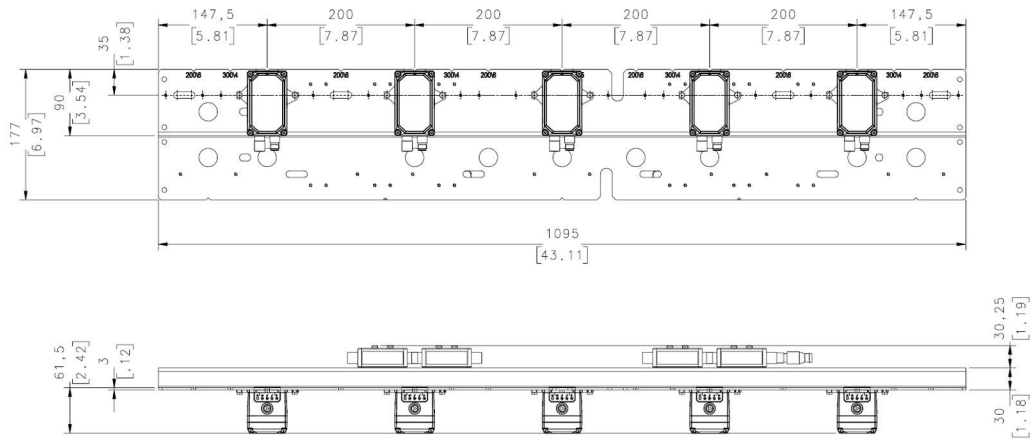

STS320-016

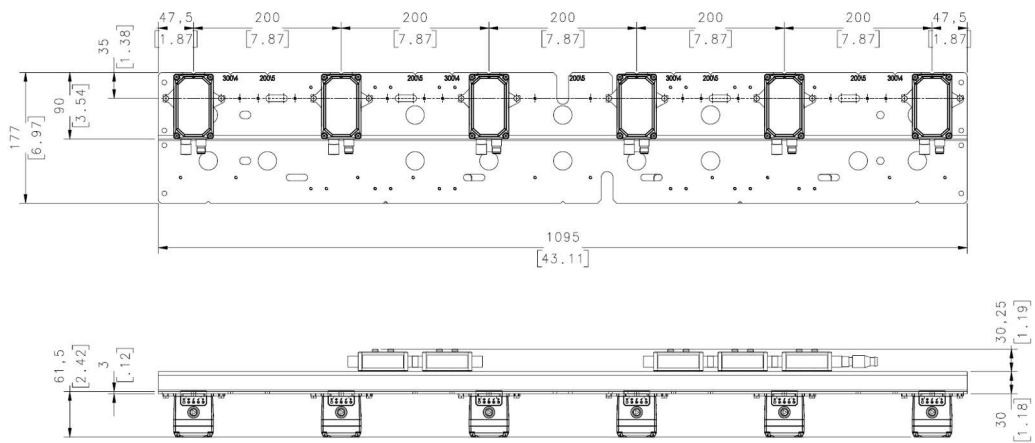

STS320-103

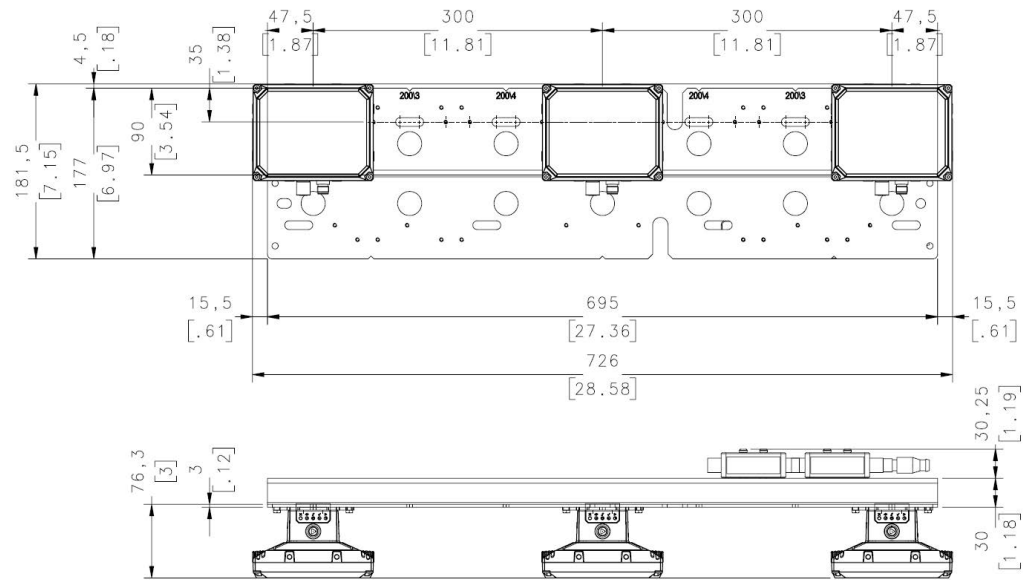

STS320-104

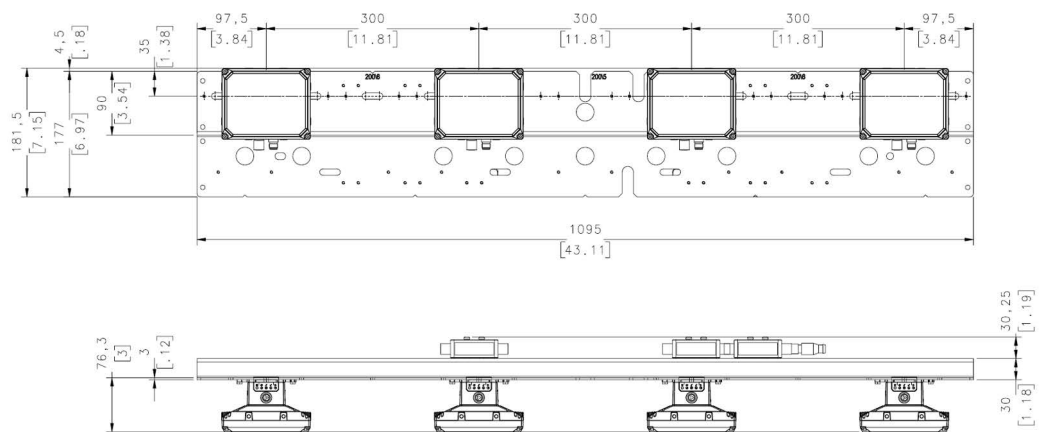

STS320-113

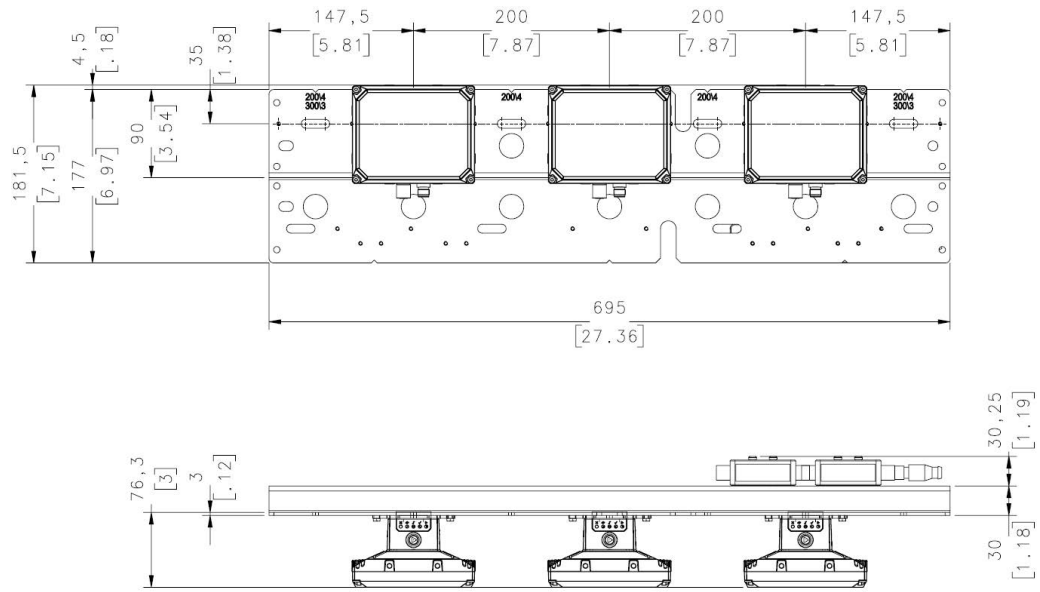

STS320-114

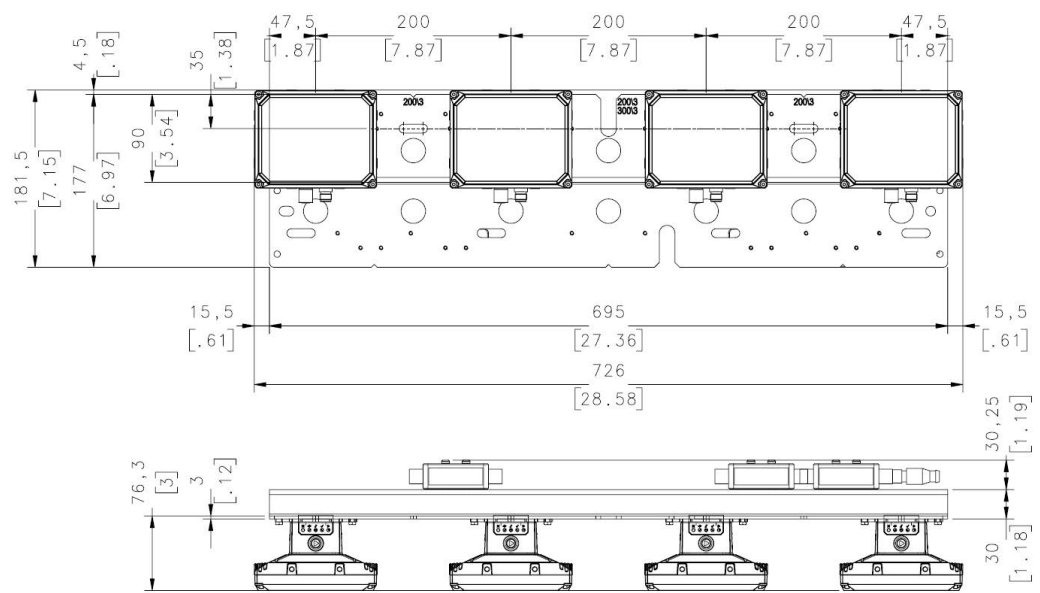

STS320-115

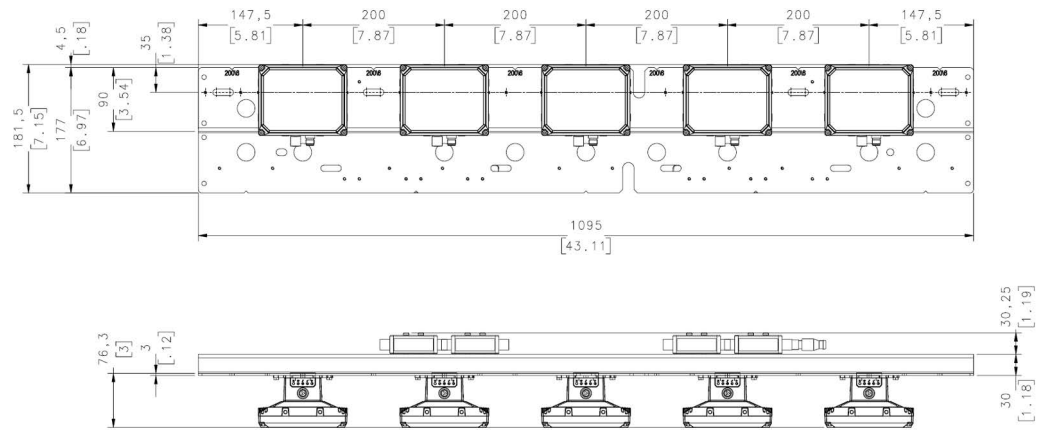

STS320-116

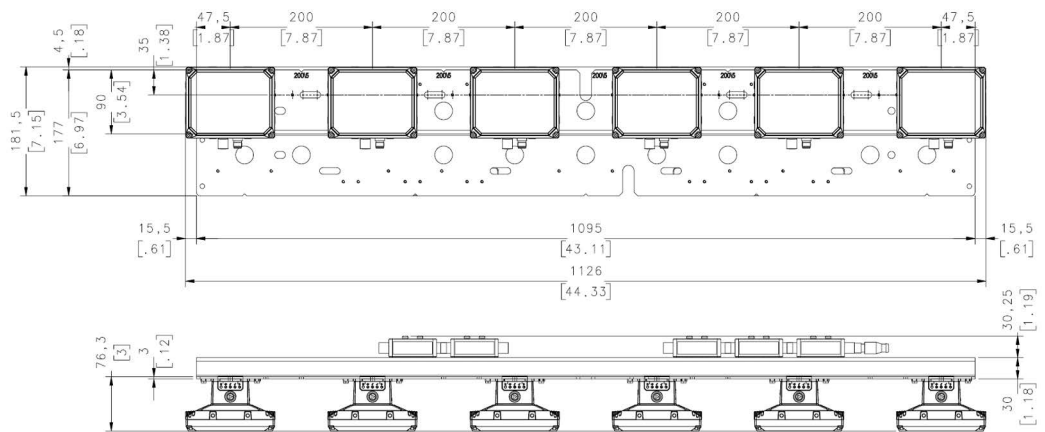

STS320-203

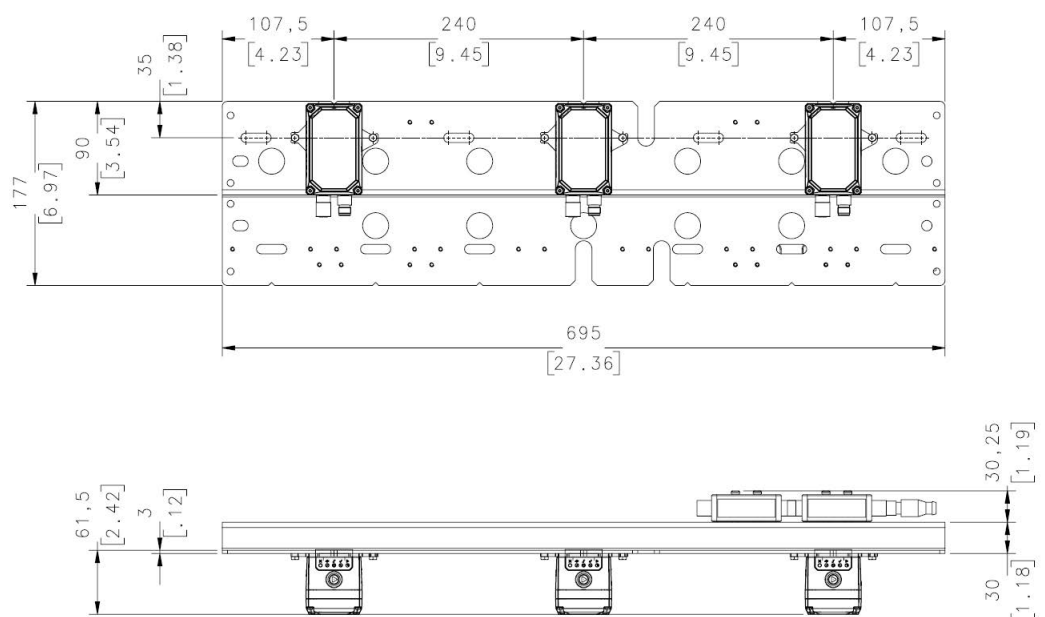

STS320-204

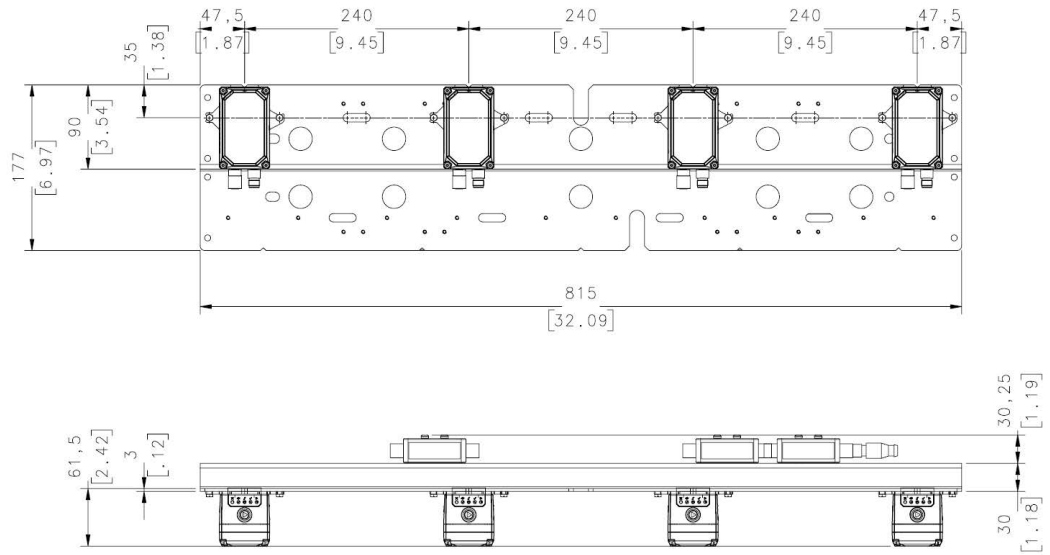

STS320-205

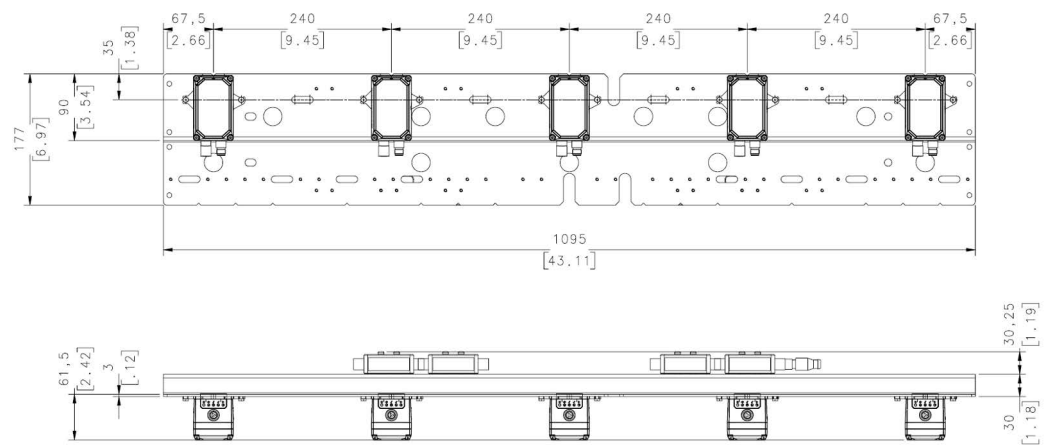



# STS320 MAIN PLATE MOUNTING

Once the supporting profile has been positioned at the correct height we can proceed with the STS320 mechanical mounting.

STS320 has been designed to be easily installed by one person using the T-bolt, special plate supporting nut and locknut supplied in the kit:

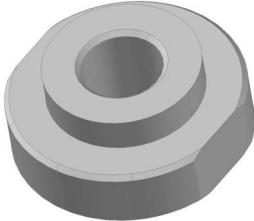

Figure 5 - STS320 Plate Supporting Nut

The plate supporting nut has to be coupled to the frame with the M8 x 25 mm T-bolt:

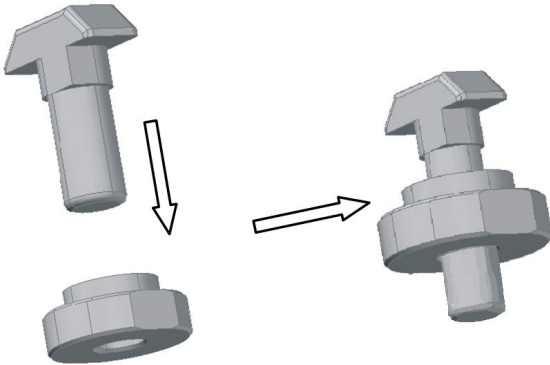
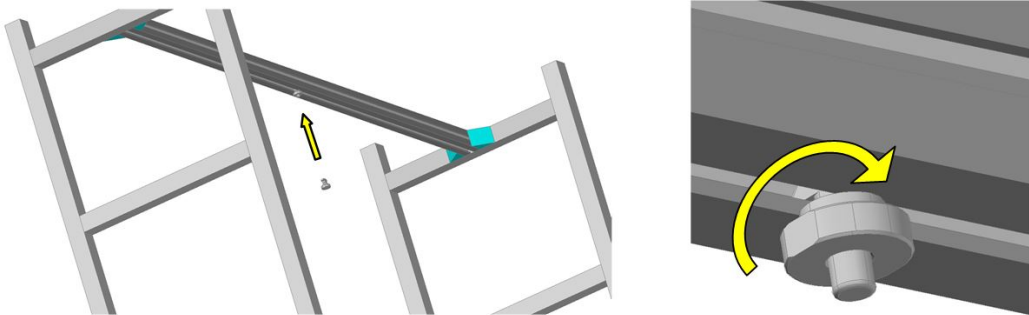

Figure 6 - STS320 Plate Support Assembly

Mount the plate support assembly onto the bottom side of the STS320 supporting frame. When the T-bolt is inserted into the profile slot, position it directly over the center<sup>1</sup> of the conveyor and completely tighten the nut:



Finally, the STS320 can be mounted onto the station frame.

1. For STS320 models with an even number of readers the main plate slot, FOV, and operating width are congruent. If the STS320 model has an odd number of readers, the central reader must be aligned with the center of the conveyor. See "STS320 Plate Support Assembly Positioning" on page 25

The STS320 has to be installed onto the station frame in the conveyor direction so that the main plate slot (reader side) is aligned with the plate support assembly.

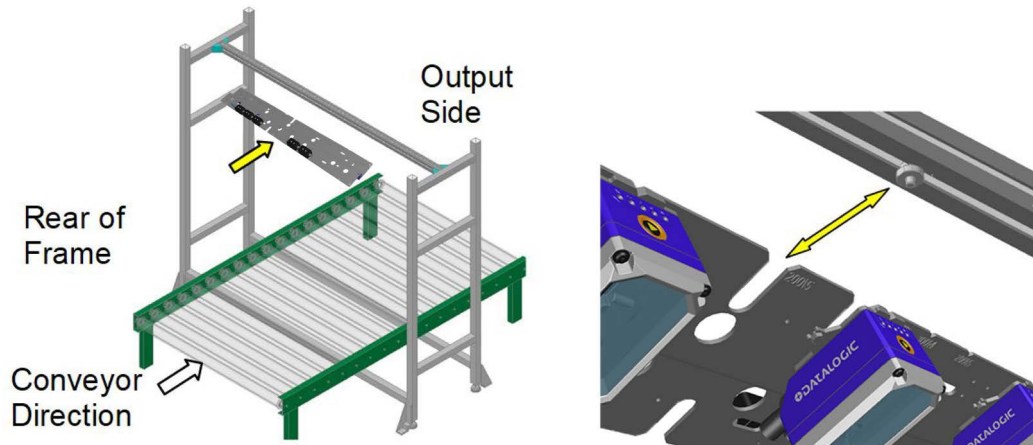

Slide the main plate slot between the plate support assembly and the supporting profile until it reaches the end.

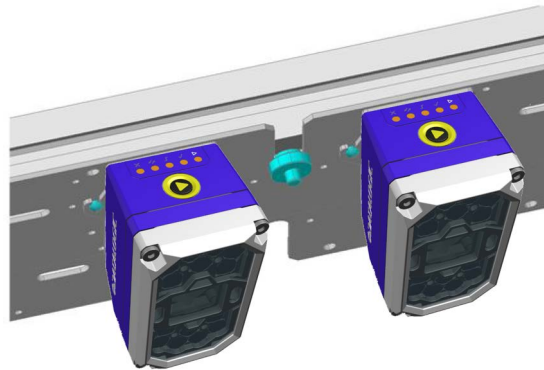

The plate support assembly can fully support the STS320 weight without human help.

Fix the STS320 using 4 T-bolts and nuts (not supplied) to the supporting profile. When the main plate slot is fully inserted onto the plate support assembly, the 4 mounting slots are aligned with the supporting profile groove:

Also screw the locknut onto the plate support assembly and tighten it.

## STS320 Plate Support Assembly Positioning

For STS320 models with an even number of readers the main plate slot, FOV, and operating width are congruent.

The following figure shows the positioning of the plate support assembly with an even number of readers:

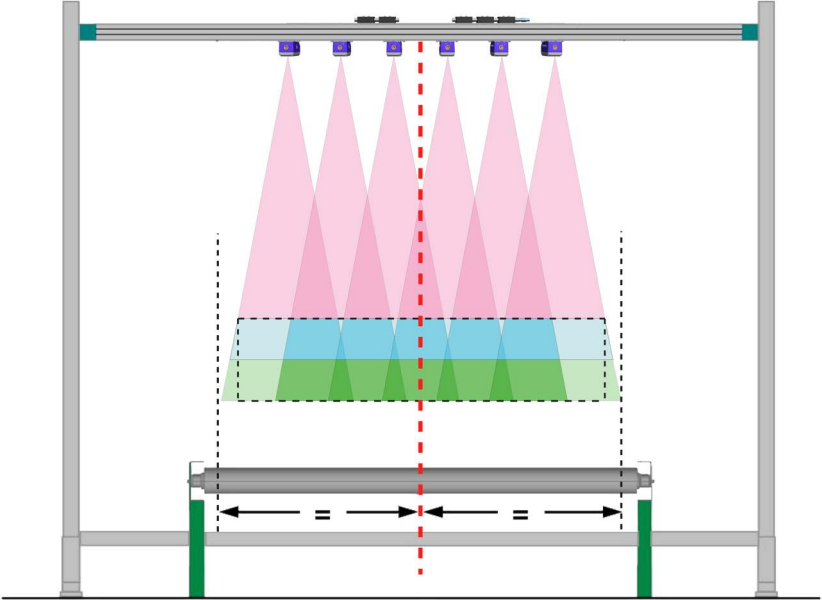

Figure 7 - STS320-xx6 positioning

On the other hand, for STS320 models with an odd number of readers, the central reader must be aligned with the center of the conveyor.

The following figure shows the positioning of the plate support assembly with an odd number of readers:

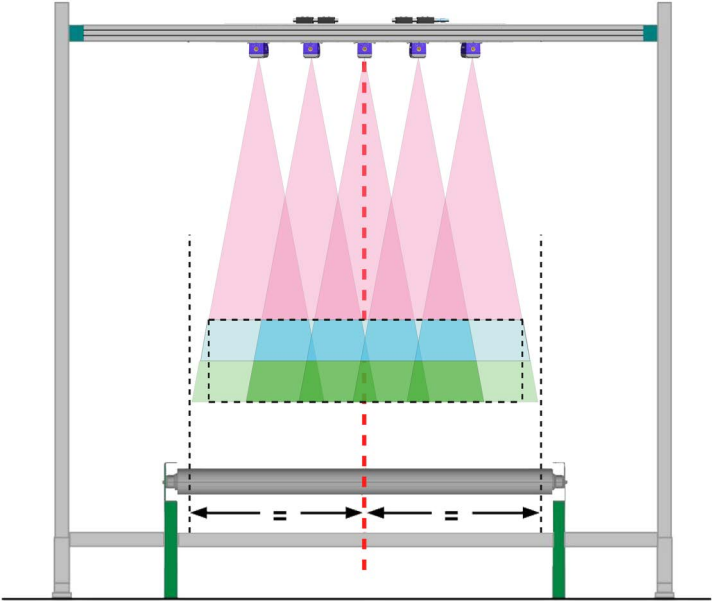

Figure 8 - STS320-xx5 positioning

## PRESENCE SENSOR POSITIONING

The STS320 system comes with a pair of photocells that can be used to detect the presence of the tire on the conveyor and trigger the beginning and the end of the reading phase. When used, they must be positioned and mounted at the conveyor belt level depending on the size of the tires that must be handled.

Position the presence sensors according to the following procedure:

1. Retrieve the size of the minimum tire height ( $H_{min}$ ) at the minimum tire width ( $W_{min}$ ).
2. Determine the field of view along the conveyor direction ( $FOV_v$ ) at the maximum distance. See the table below.

Model	Typical FOV @ Max. Distance
STS320-00x	260 mm
STS320-01x	211 mm
STS320-10x	305 mm
STS320-11x	214 mm
STS320-20x	247 mm

3. If the minimum tire height ( $H_{min}$ ) is less than the  $FOV_v/2$  at the maximum distance, then both Reading Phase ON and Reading Phase OFF presence sensors are required and they must be mounted at the  $H_{min}$  distance from the edges of the vertical FOV as shown in the figure below:

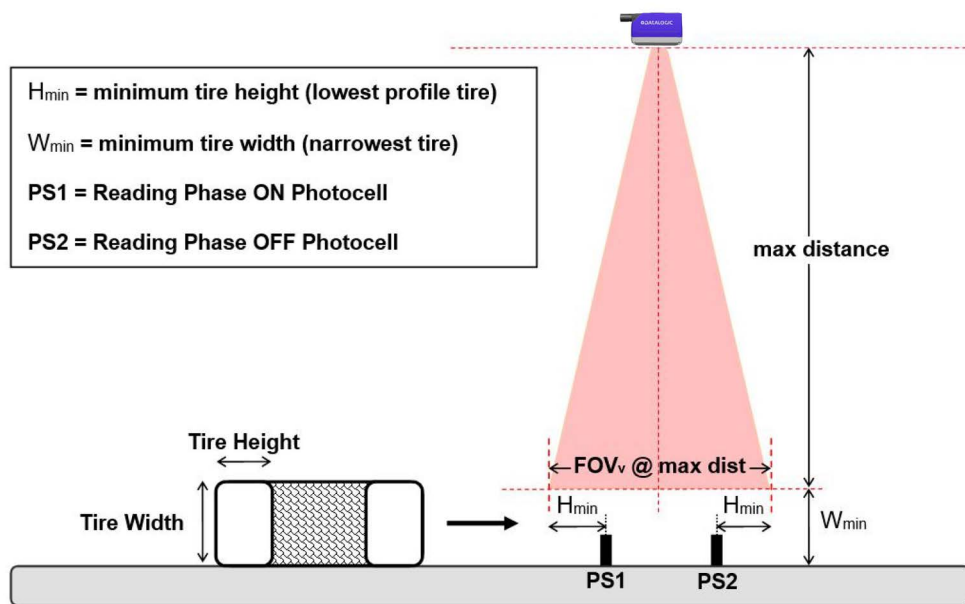

Figure 9 - Top reading station with two presence sensors

In some cases the system can work with only one photocell.

If the minimum tire height ( $H_{min}$ ) is greater than the  $FOV_v/2$  at the maximum distance, then only a single presence sensor is required and it must be mounted at the mid point of the field of view as shown in Figure 10:

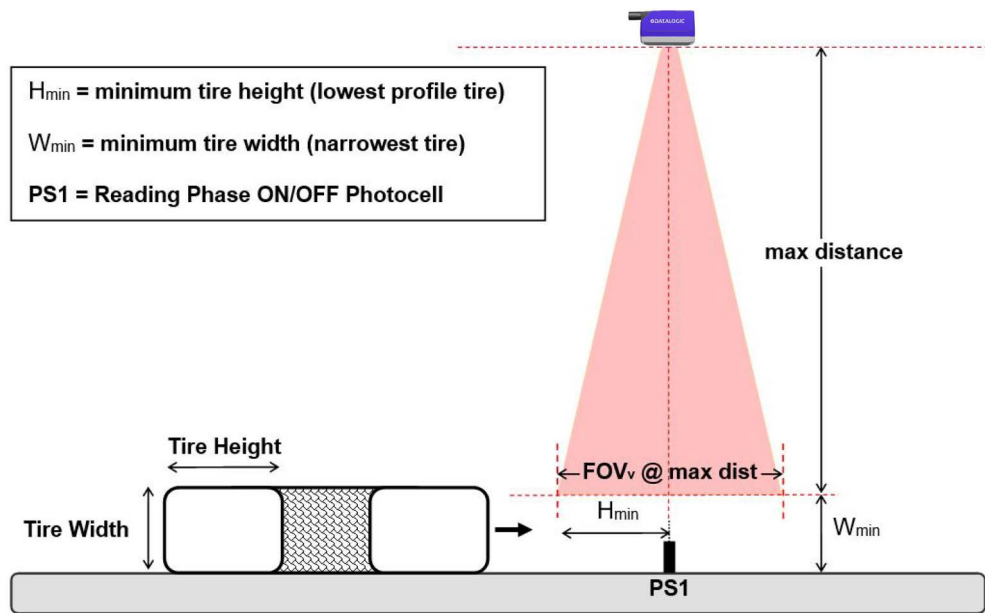
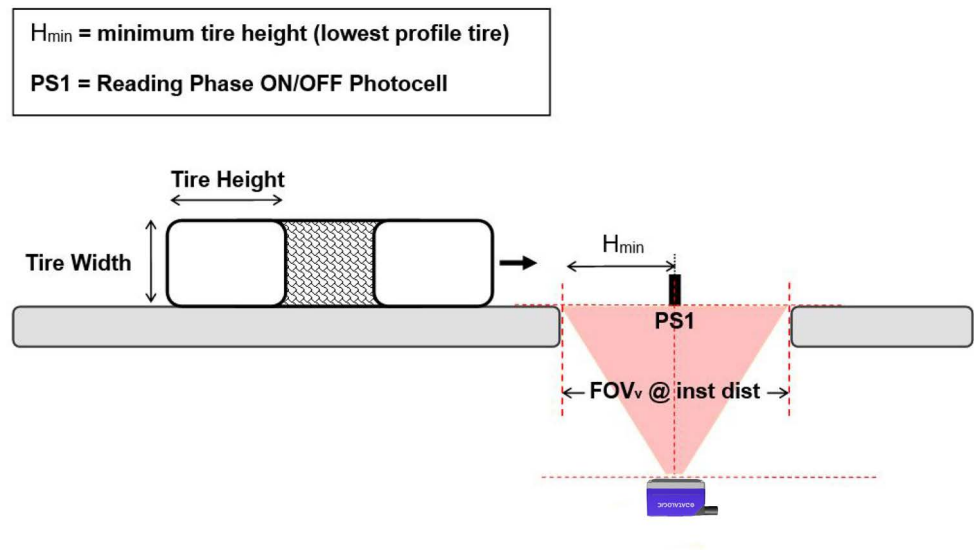

Figure 10 - Top reading station with single presence sensor



**NOTE**

This configuration requires modifying the Master default Reading Phase OFF parameter to External Trigger Trailing Edge, Complete Read.



**NOTE**

For Bottom Reading Stations installed at the minimum nominal reading distance of 280 mm (11.02 in), the Vertical FOV is 157 mm (6.18 in). If allowed by the application, it is suggested to use this value for the conveyor gap to maximize the reading area.

Smaller gaps can be used and maximized by modifying the configuration. Please contact your local Datalogic representative for feasibility.

# MATRIX 320 ATS

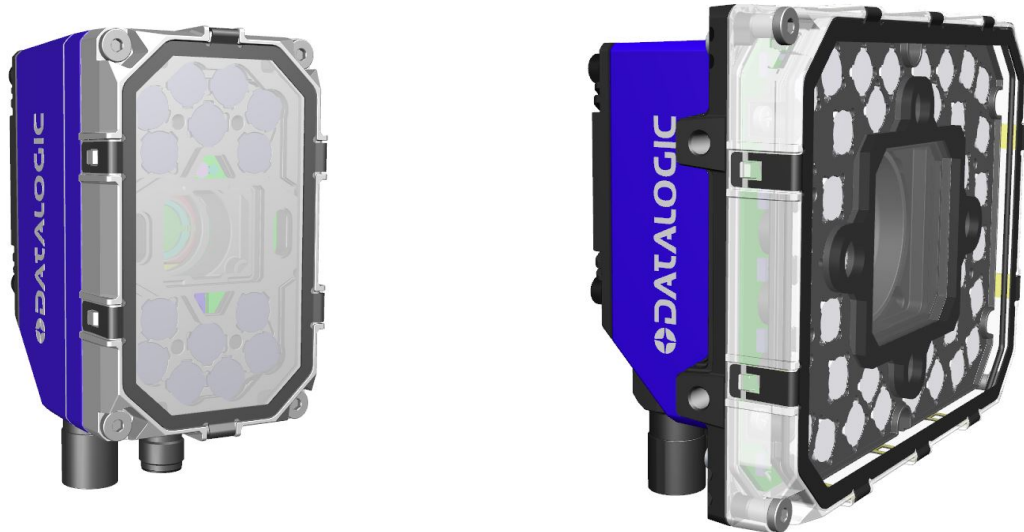

Single Matrix 320™ ATS-xxx models are used as replacement readers for the related STS320 stations.

However, they can also be used as stand alone readers having the same characteristics as the related application type STS320 models.

## Matrix 320 ATS as Replacement Reader

When used a replacement reader, the correct Matrix 320 ATS model must be selected for the STS320 station used, as shown in the table below:

Matrix 320 ATS Model	Matrix 320 ATS Order No.	Corresponding STS320 station
Matrix 320 ATS-000	938100036	STS320-00x
Matrix 320 ATS-010	938100037	STS320-01x
Matrix 320 ATS-100	938100038	STS320-10x
Matrix 320 ATS-110	938100039	STS320-11x
Matrix 320 ATS-200	938100040	STS320-20x

To replace a reader included in the STS320 station, follow the procedure described in "Replacement" on page 50.

## Matrix 320 ATS as Stand Alone Reader

When Matrix 320 ATS is used as a stand alone reader, data included in "Matrix 320 ATS Mounting Distance" on page 29 must be considered.

The stand alone reader must be connected to a CBX connection box through one of the available CAB-DSxxS accessory cables. A CAB-xxxxx-ETH is also necessary.

Refer to "Electrical Connections" on page 30 for more information on CBX and presence sensors connection.

Also note that Matrix 320 ATS used as a stand alone reader is completely configurable through DL.CODE. Refer to the DL.CODE User’s Manual for more information.

To save a configuration on a BM100 module, refer to "Backup and Restore Through DL.CODE" on page 49.

### Matrix 320 ATS Mounting Distance

Model	Code Resolution	Reading Width @ min. distance	DOF*	Min. Reading Distance	Max. Reading Distance	Focus Distance	Vertical FOV @ min. distance
	mm (mils)	mm (in)	mm (in)	mm (in)	mm (in)	mm (in)	mm (in)
Matrix 320 ATS-000	0.30 (12)	359 (14.13)	250 (9.84)	830 (32.68)	1080 (42.52)	940 (37.01)	202 (7.95)
Matrix 320 ATS-010	0.25 (10)	270 (10.63)		620 (24.41)	870 (34.25)	730 (28.74)	152 (5.98)
Matrix 320 ATS-100	0.35 (14)	375 (14.76)	400 (15.75)	850 (33.46)	1250 (49.21)	1000 (39.37)	211 (8.31)
Matrix 320 ATS-110	0.25 (10)	258 (10.16)		830 (32.68)	1230 (48.43)	970 (38.19)	145 (5.71)
Matrix 320 ATS-200	0.30 (12)	300 (11.81)	170 (6.69)	280 (11.02)	450 (17.72)	330 (12.99)	157 (6.18)

\* DOF = Max. Reading Distance - Min. Reading Distance

# CHAPTER 3

## ELECTRICAL CONNECTIONS

### STS320 WIRING DIAGRAM

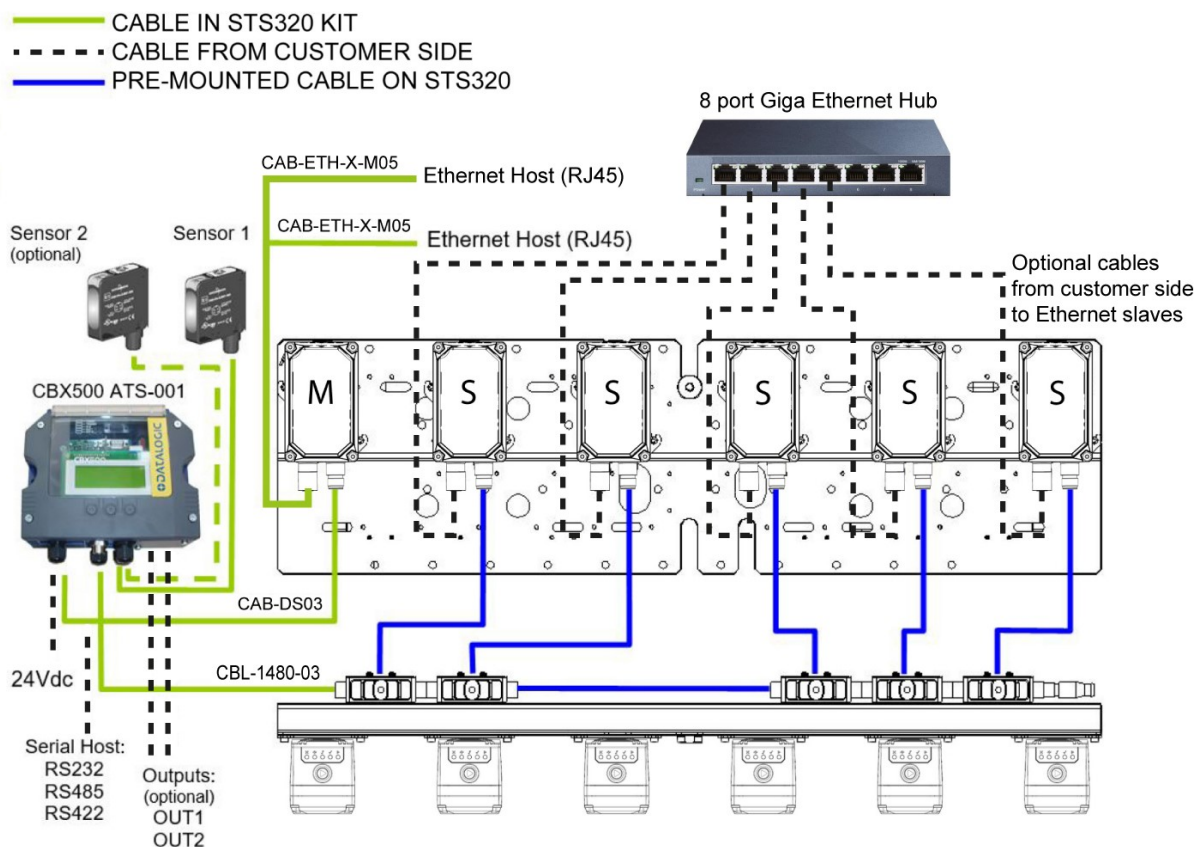
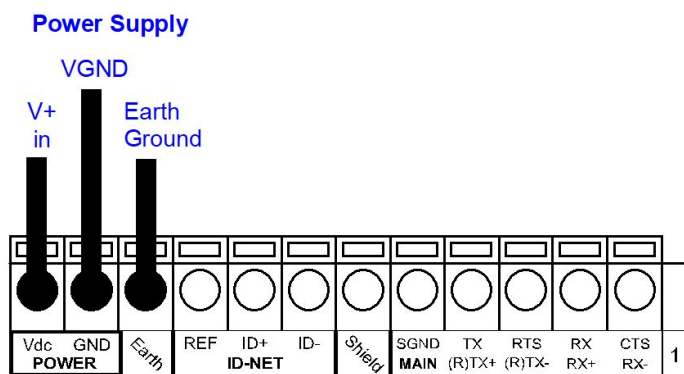

Figure 11 - STS320 Array Wiring



## POWER SUPPLY

Power is supplied through the CBX500 ATS spring clamp terminal pins as shown in the figure below.



**Figure 12 - Power Supply Connections**

For all STS320 models the power must be 24 Vdc only.

It is recommended to connect the array CHASSIS to earth ground (Earth) by setting the appropriate jumper in the CBX connection box. See the CBX Installation Manual for details.

## M12 X-CODED 8-PIN CONNECTOR (ETHERNET)

An M12 X-Coded connector is provided for the on-board Ethernet connection. This interface is IEEE 802.3 10 BaseT, IEEE 802.3u 100 BaseTx, and IEEE 802.3ab 1000BaseT compliant.

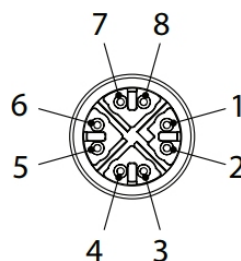

**Figure 13 - M12 X-Coded Female Ethernet Network Connector**

M12 X-Coded Ethernet Network Connector pinout		
Pin	Name	Function
1	DA+	Bidirectional data DA+
2	DA-	Bidirectional data DA-
3	DB+	Bidirectional data DB+
4	DB-	Bidirectional data DB-
5	DD+	Bidirectional data DD+
6	DD-	Bidirectional data DD-
7	DC-	Bidirectional data DC-
8	DC+	Bidirectional data DC+

## DIGITAL INPUTS

There are two optocoupled polarity insensitive inputs available on the reader: Input 1 (External Trigger) and Input 2, a generic input:

These inputs can be used to control (start/stop) the reading phase:

Parameter Source	Reading Phase ON Input	Reading Phase OFF Input
Single Presence Sensor	External Trigger Leading Edge	External Trigger Trailing Edge
Two Presence Sensors	External Trigger Leading Edge	Input 2 Leading Edge
PLC Digital Output	External Trigger Leading Edge or Input 2 Leading Edge	External Trigger Trailing Edge or Input 2 Trailing Edge

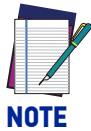

### NOTE

**Alternatively, host communication output commands (Serial or Fieldbus) can be used to control the reading phase. See the Configuration Parameters Help On Line for details.**

The electrical features of both inputs are:

$$V_{AB} = 30 \text{ Vdc max.}$$

$$I_{IN} = 10 \text{ mA (reader) + 12 mA (CBX) max.}$$

The active state of these inputs is selected in software.

An anti-disturbance filter is implemented in software on both inputs so that the minimum pulse duration is  $\cong 0.5$  milliseconds. This value can be increased through software.

These inputs are optocoupled and can be driven by PNP type commands.



### NOTE

**Polarity insensitive inputs assure full functionality even if pins A and B are exchanged.**

## Input Connections for Presence Sensors (provided in the package)



### NOTE

Power is available directly to the Input Device, independently of the Power Supply Switch inside the CBX.

The sensors included in the STS320™ have a standard pinout (brown = +Vdc; blue = GND; black = switched) and can be connected to the Trigger and Input 2 as shown in the figures below.

Sensor 1	CBX500 ATS Row 2	Function
brown	+V	Power Source - External Trigger
black	I1A	External Trigger A (polarity insensitive)
blue	I1B	External Trigger B (polarity insensitive)
blue	-V (bridge to I1B)	Power Reference - External Trigger

### Presence Sensor Photocell (PNP)

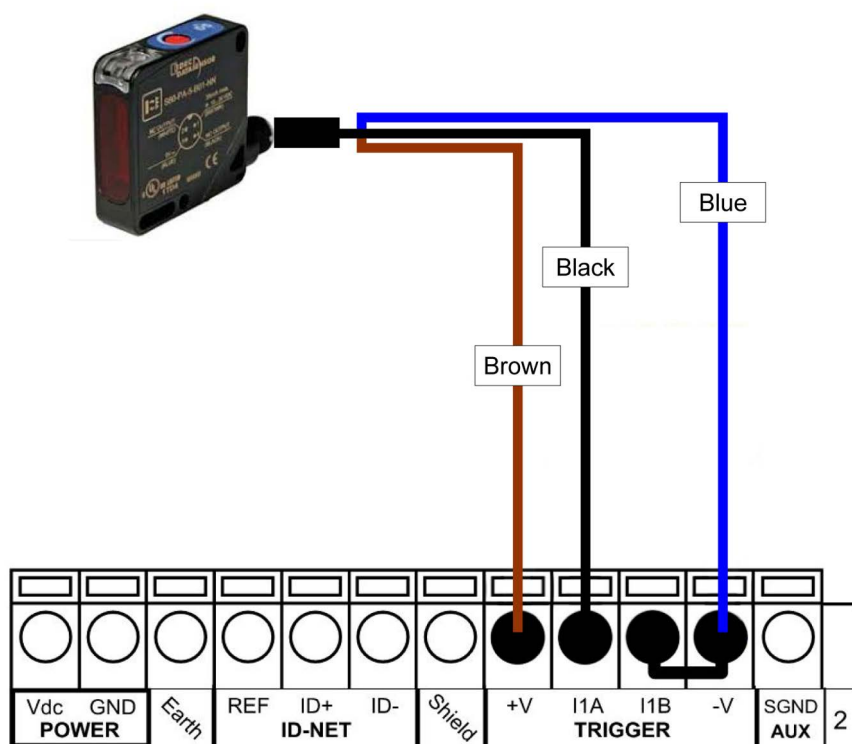
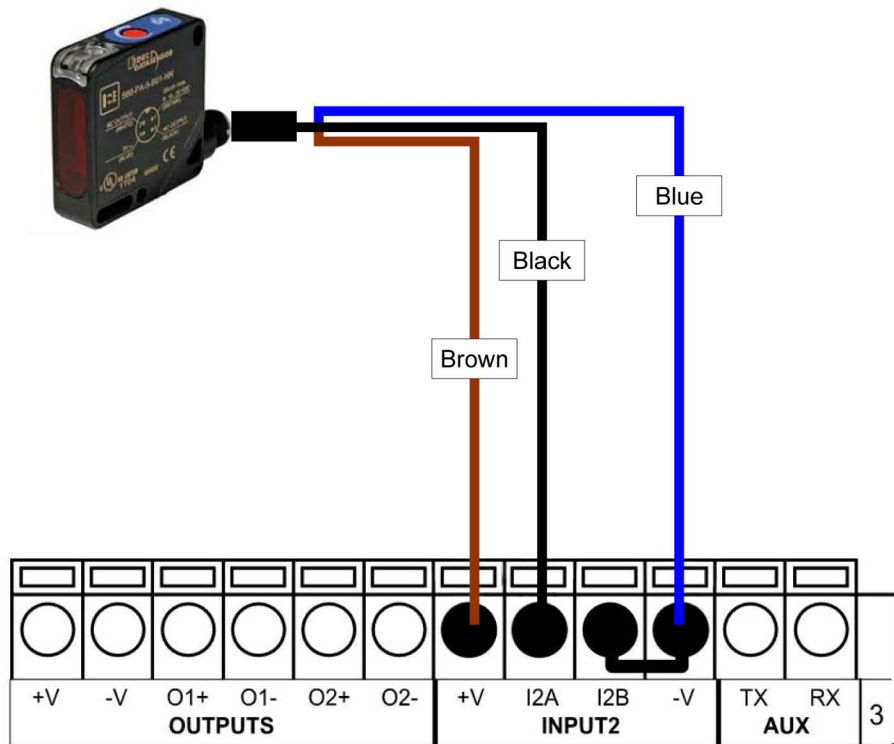

Figure 14 - Presence Sensor connected to External Trigger

The yellow Trigger LED on the reader is on when the active state of the External Trigger corresponds to ON.

Sensor 2	CBX500 ATS Row 2	Function
brown	+V	Power Source - External Trigger
black	I2A	Input 2 A (polarity insensitive)
blue	I2B	Input 2 B (polarity insensitive)
	-V (bridge to I2B)	Power Reference - Inputs

**Presence Sensor Photocell (PNP)**



**Figure 15 - Presence Sensor Connected to Input 2**

**Input Connections from PLC**

Alternatively, the reading system can be controlled by a digital output of a PLC. For this purpose, connect the switched signal and the appropriate reference level as shown in the figures below.

PLC Signal	CBX500 ATS Row 2	Function
Input	I1A	External Trigger A (polarity insensitive)
Reference	I1B	External Trigger B (polarity insensitive)

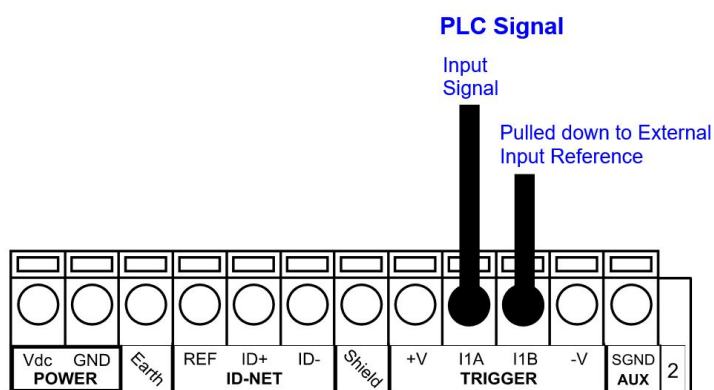

Figure 16 - External Trigger Connected to PLC

The yellow Trigger LED on the reader is on when the active state of the External Trigger corresponds to ON.

PLC Signal	CBX500 ATS Row 3	Function
Input	I2A	Input 2 A (polarity insensitive)
Reference	I2B	Input 2 B (polarity insensitive)

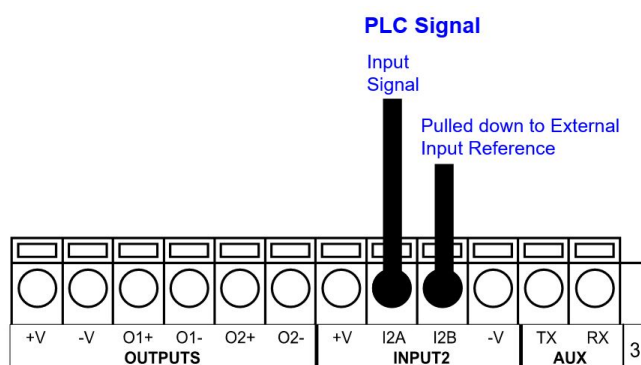

Figure 17 - Input 2 Connected to PLC

## DIGITAL OUTPUTS

Three short-circuit protected outputs are available that can be configured as NPN, PNP and PP. Using a CBX connection box, the first two outputs are opto-coupled. The meaning of the three outputs can be defined by the user. They are typically used to signal the data collection result. They are also available to the Host (either serial or Fieldbus) to be driven independently.

The electrical features of the two outputs are the following:

$$V_{OUT} (I_{LOAD} = 0 \text{ mA}) \text{ max. } 24 \text{ Vdc}$$

$$V_{OUT} (I_{LOAD} = 100 \text{ mA}) \text{ max. } 3 \text{ Vdc}$$

$$I_{LOAD} \text{ max. } 100 \text{ mA}$$

By default, Output 1 is associated with the Partial Read and No Read events, which activates when the code(s) signaled by the external trigger are not decoded, and Output 2 is associated with the Complete Read event, which activates when all the selected codes are correctly decoded. The output signals are fully programmable through DL.CODE.

# Output Connections Using STS320 Power



**Power is available directly to the Output Device, independently of the Power Supply Switch inside the CBX.**

The digital outputs can power and drive small devices meeting the electrical characteristics above such as electronic switches which can then manage larger power consuming devices such as signaling lights or other machinery.

CBX500 ATS	Function
+V	Power Source - Outputs
O1+	Output 1 +
O1-	Output 1 -
O2+	Output 2 +
O2-	Output 2 -
-V	Power Reference Outputs

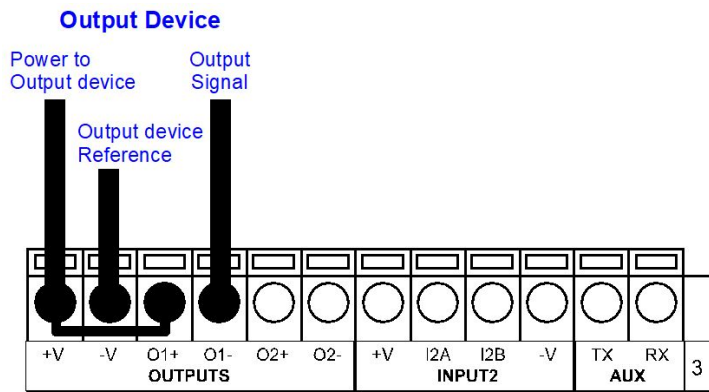

**Figure 18 - Open Emitter Output using STS320 Power**

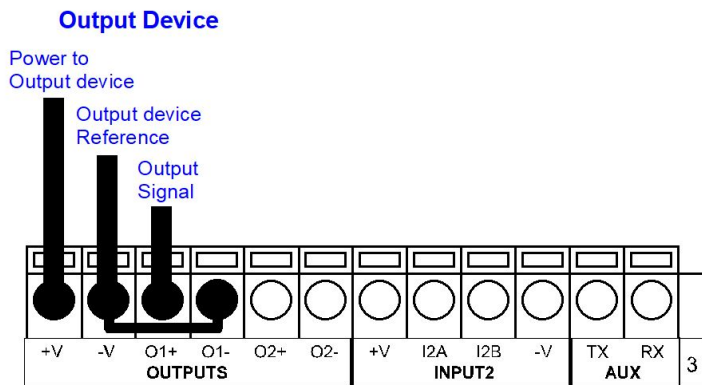

**Figure 19 - Open Collector Output using STS320 Power**

# CHAPTER 4

## DISPLAY MENUS

---



### NOTE

**While working on the display the complete reading station is offline. The Offline state means that no readings are performed, no data is transmitted to the PLC and any connection to DL.CODE will be lost. The display menus allow you to: change the messages on the display (View), perform backup and restore, and reset the counters.**

If the reading station is turned on and the system is ready, the master-reader shows the most important values on the display.

```
Matrix 320 ATS-XXX
6.xx          SYN M00
SN XXXXXXXXXX
ETH XXX.XXX.XXX.XXX
```

The display can be used with the three buttons below it. The up arrow button allows you to scroll up through the menu. The down arrow button allows you to scroll down through the menu. With the middle button, you can confirm your selection.



To access the menu, press the two outermost buttons simultaneously for several seconds.

## MAIN MENU

To enter the Menu press the Up and Down buttons simultaneously. The menu structure is shown below.

**Menu: [Exit]** (exits HMI Interface menu)

- Test Mode
- Focus/Locate
- Calibration
- Code Setting
- View

**Extended** (enters Extended menu)

**Extended: [Exit]** (returns to Main menu)

- Backup
  - Yes** (performs Backup - uninterruptible)
  - No** (returns to Extended menu)
- Restore
  - Yes** (performs Restore - uninterruptible)
  - No** (returns to Extended menu)

To move through the list press and release the **Up** or **Down** key.

To select an item or enter a submenu, press and release the **Enter** key. After executing an HMI function the display shows a result message and then automatically exits from the menu structure.

To exit a menu, press and release the **Enter** key at the [Exit] item.

To exit from a running HMI function, press and release the **Enter** key. These functions will also exit upon their configured timeout.



## VIEW MENUS



### NOTE

This menu item is only visible if the connected reader is set as master.

Using this menu item, you can select between different views to be shown on the display.

## Standard

In this standard view the following content will be shown on the display:

Row 1: Reading Result

Rows 2 and 3: Code Content

Row 4: Number of digits in code and Angle of code in image

Good Read	Good 1234567890  0010 Dgt 351 Deg
No Read	No Read
Reading Active	Reading ...

## Network State

In this view the state of the slave readers, connected to the ID-NET™ network, can be checked. Below the address number the status of the reader is displayed as a symbol.

No Error	1 Network 15 *****----- 16 Network 31 -----
Slave 2 missing	1 Network 15 *?***----- 16 Network 31 -----

\* = Reader with no error

! = Reader with an error

? = Reader missing ID-NET network

## EXTENDED MENU

Through menu item the parameters and calibrations of the complete system will be backed up or restored in the BM100 backup module inside the CBX500 (see "Backup procedure" on page 42).

# CHAPTER 5

## SOFTWARE CONFIGURATION

---

There are two main methods that can be used to complete the STS320 installation.

The first regards stations that do not need any application specific parameter configuration. The factory default configuration is sufficient and the only necessary steps are to align the Master IP Address to the Host LAN through a web browser using the Web Discovery feature, then backup the configuration through the CBX500 menu.

The second method requires installation of the DL.CODE configuration program. Through DL.CODE, IP Addresses are aligned, application specific parameters are configured, and backup procedures are performed both to the external storage device (BM100), as well as to a file.

### STS320 DEFAULT CONFIGURATION

<b>Default IP Address</b>	192.168.3.100
<b>Code symbologies</b>	CODE128, CODE39, INT20F5 (min. 8 digits)
<b>Layout type</b>	Synchronized
<b>Operating mode</b>	Phase mode Phase ON: Input 1 - Leading Edge Phase OFF: Input 2 - Trailing Edge
<b>Acquisition trigger</b>	Periodic (25 ms)
<b>Data collection type</b>	Code combination (1 expected code)
<b>Output</b>	<ul style="list-style-type: none"><li>• Good Read: Output 2, Green Spot, 360° Green Feedback</li><li>• No Read: Output 1, Red Spot, 360° Red Feedback</li><li>• Configuration Mode: 360° Blue Feedback</li></ul>
<b>Output Message 1</b>	Event Type: Good Read, Output Channel: TCP Server (port 51236), Message content: <STX><CodeContent><CR><LF>
<b>Output Message 2</b>	Event Type: No Read, Output Channel, TCP Server (port 51236), Message content: <STX><CAN><CR><LF>

### CONFIGURATION USING WEB DISCOVERY

Devices can be discovered via web interface. To do this, from either the Host PC or configuration PC connected to the network, open your browser and go to <http://data-logic.local/>.

This page shows all devices available in the network:

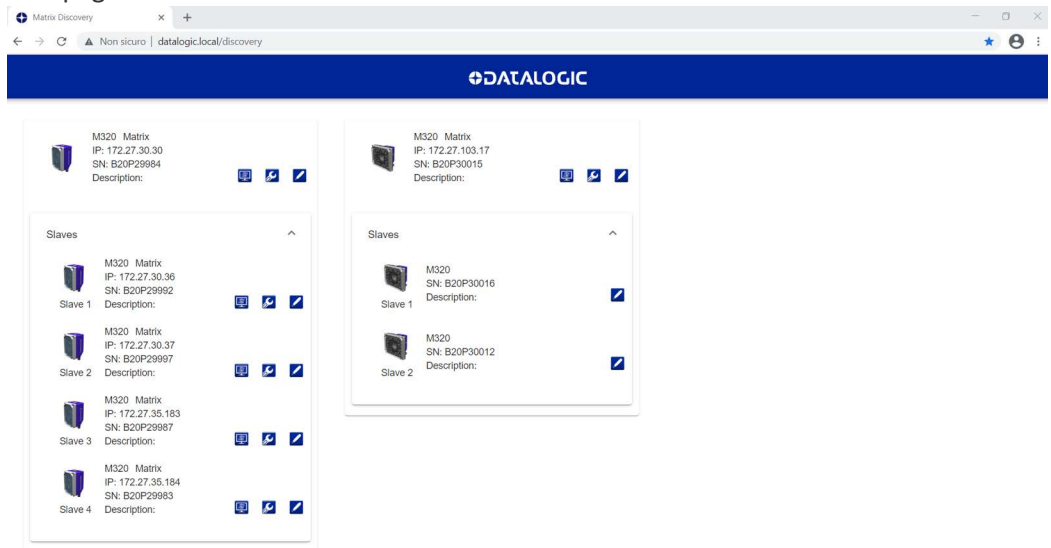



Click on the wrench icon and input the correct IP Address settings (from network administrator) and optional Device Description for each reader.



**At least one device must be reachable from the user PC. For example, if there are several subnetworks, at least one device must be in the same subnetwork of the PC.**

The following functions are available for each discovered device:

	<p>Open the Web Monitor page of the selected device.</p>
	<p>Display and configure the Ethernet settings, as shown in the figures below (left: device in DHCP mode<sup>a</sup>; right: device in Static mode):</p> <div style="display: flex; justify-content: space-around;"> <div data-bbox="699 1485 986 1709"> <p><b>Ethernet Settings</b></p> <p>MAC Address: <input type="text" value="00:07:BE:09:07:CF"/></p> <p>Use DHCP: <input checked="" type="checkbox"/></p> <p><input type="button" value="OK"/></p> <p><input type="button" value="Cancel"/></p> </div> <div data-bbox="1034 1361 1321 1709"> <p><b>Ethernet Settings</b></p> <p>MAC Address: <input type="text" value="00:07:BE:07:AB:AB"/></p> <p>Use DHCP: <input type="checkbox"/></p> <p>IP Address: <input type="text" value="192.168.3.100"/></p> <p>Subnet Mask: <input type="text" value="255.255.255.0"/></p> <p>Gateway Address: <input type="text" value="0.0.0.0"/></p> <p>DNS1 Address: <input type="text" value="0.0.0.0"/></p> <p><input type="button" value="OK"/></p> <p><input type="button" value="Cancel"/></p> </div> </div>
	<p>Set the device description. In case of Slave devices, this button is only available if the corresponding Master device is reachable.</p> <div data-bbox="866 1814 1153 1989"> <p><b>Device Description</b></p> <p>Device Description: <input type="text"/></p> <p><input type="button" value="OK"/></p> <p><input type="button" value="Cancel"/></p> </div>

a. Use DHCP addressing only if the network is connected to a DHCP Server.

# BACKUP PROCEDURE USING CBX500 HMI INTERFACE

## Keypad and Display

The CBX500 display can be used with the three buttons below it. The up arrow button allows you to scroll up through the menu. The down arrow button allows you to scroll down through the menu. With the middle button, you can confirm your selection:



To access the menu, press the two outermost buttons simultaneously for several seconds. The menu structure is shown below.

**Menu: [Exit]** (exits HMI Interface menu)

Test Mode  
Focus/Locate  
Calibration  
Code Setting  
View

**Extended** (enters Extended menu)

**Extended: [Exit]** (returns to Main menu)

Backup  
  **Yes** (performs Backup - uninterruptible)  
  **No** (returns to Extended menu)  
Restore  
  **Yes** (performs Restore - uninterruptible)  
  **No** (returns to Extended menu)



### NOTE

**NEVER select the “Focus/Locate” or “Calibration” items.**

## Backup procedure

1. Make sure the Write Protection switch (inside the CBX500) on the BM100 is unlocked.
2. Select the Backup item from the Extended menu and press the Enter key on the **Yes** item.
3. When the procedure is complete a message appears on the display showing the results (**Done** or **Error**).
4. Set the Write Protection switch to locked.

After performing the Backup installation is completed. You can check the station performance using the Web Monitor.

# WEB MONITOR

Web Monitor is a remote monitoring tool provided to visualize STS320 in its run-time environment. You can access it from the DL.CODE Task area, from the Discovery page, or from your browser by inputting the IP address of the reader. STS320 must be available on the LAN.

This works on major browsers (also on smartphones and tablets), which support HTML5.

Chrome	Firefox	Edge	IE	Safari	iOS	Android	IE Mobile
latest	latest	14	11	10	10	Nougat (7.0) Marshmallow (6.0)	11
		13	10	9	9	Lollipop (5.0, 5.1)	
			9	8	8	KitKat (4.4.)	
				7	7	Jelly Bean (4.1, 4.2, 4.3)	



The Web Monitor tool provides the following features:

## Info page

DATALOGIC	
<b>Device Info</b>	
Device Name	M300Nsempini2
Model	M300N 482-010
Serial number	C16E06670
Software Version	1.6.2.21-BETA02
<b>Current Device Configuration</b>	
Running	Trending
Startup	Trending
<b>Network Info</b>	
DHCP	Disabled
IP Address	10.239.37.191
Subnet Mask	255.255.248.0
Gateway	0.0.0.0
MAC Address	00:07:BE:02:57:0A

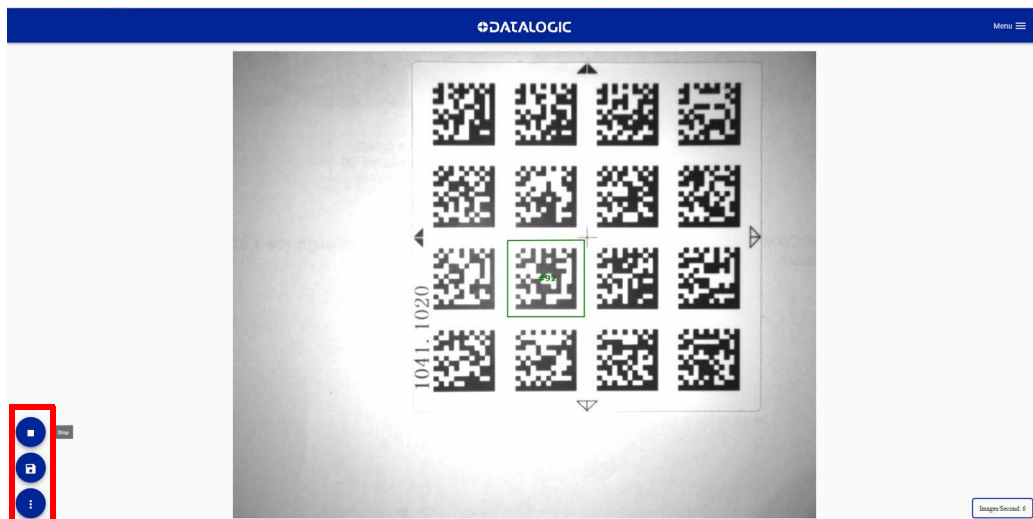
## Monitoring Page



	<p>The Stop/Play button allows you to stop image monitoring to save a particular image. The reader continues to run, only the monitored image is stopped.</p>
	<p>The Save image button automatically downloads the current image as a jpg file to the browser's default Download folder. The default naming syntax is <code>image_weekday month day year.jpg</code> (i.e. <code>image_Wed Jan 23 2019.jpg</code>)</p>
	<p>The options button opens an options panel on the Monitoring window which allows:</p> <ul style="list-style-type: none"> <li>- setting the quality of the image to monitor (higher quality images reduce framerate)</li> <li>- showing only positive results (good read), only negative results, or all results</li> <li>- showing Code List</li> <li>- showing Web Monitor images per second</li> <li>- showing x,y Coordinates to the Monitoring window. The coordinates report the mouse position over the monitored image (in pixels).</li> </ul> <p>To close the options panel, click on the image area.</p>

## Statistics Page

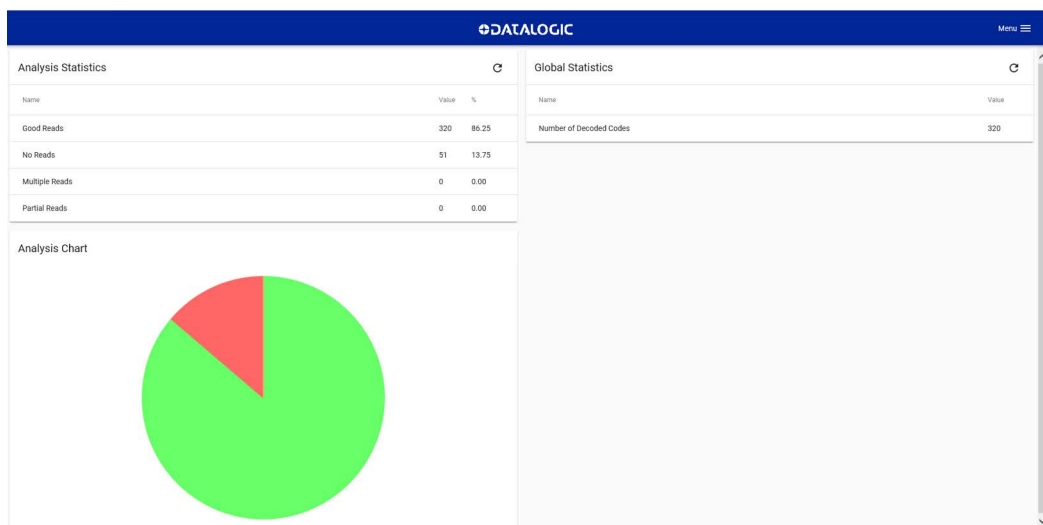

## Diagnostics Page

Alarm Code	Description	Status
1	Slave No Reply	●
64	Slave Address Duplication	●
171	Protocol Index Failure	●
185	Backup Memory Communication Failure	●
187	Wrong Rotary Switch Selection	●
189	Fieldbus Communication Failure	●
191	Fieldbus Type Mismatch	●
193	Fieldbus Configuration Error	●
195	Fieldbus DHCP Problem	●
301	SC5000 Communication Failure	●
302	SC5000 Response Failure	●
999998	Camera Head Failure	●

## Web Mosaic

The Web pages of the Master reader include the Mosaic view, which is helpful to check the system behavior at a glance.

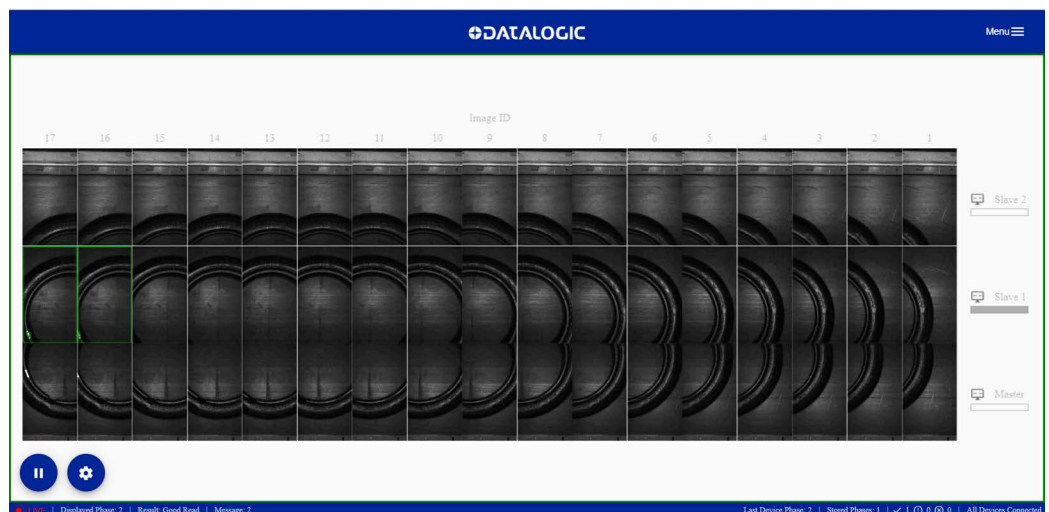

As shown in the figure above, a scaled version of the images acquired in each reading phase is retrieved from all readers and arranged side by side in a single frame.

The Mosaic view provides two main operating modes: Live and Pause. It is possible to switch between both modes using the button at the bottom left of the page.

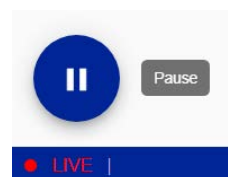

In **Live Mode**, the page is automatically updated at the end of each reading phase.

The phase result is shown by a colored box around the entire frame (green for Good Read, red for No Read, yellow for an Unreadable Code detected). Single images with a Good or an Unreadable code are colored as well.

The 20 most recent reading phases are stored in temporary memory and can be retrieved by switching to **Pause Mode** and using the arrow buttons (Pause Mode stops image collection).

In Pause Mode, images can be zoomed in with the Zoom button and the mouse wheel, and saved in a single .png file using the Save button:



In both operating modes, details of the currently displayed phase are shown in the status bar:



A histogram bar next to each device name shows how often the reader has contributed to a successful decoding (statistics refer to the phases currently stored).

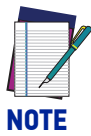

**NOTE**

**The Mosaic view is intended to be a real-time monitoring tool. If the connection to the readers is not fast enough to support the required image transmission rate, some images might be skipped (a gray box is shown as a placeholder).**

**To ensure best performance, Ethernet connection for all readers in the array is recommended.**

**If no Ethernet connection is available for one or more Slave devices, the corresponding images will be retrieved through the ID-NET internal network at thumbnail resolution, with an image skip ratio that is dependent on the number of such devices.**

Clicking on the gear icon opens a pane showing the monitoring status of each device, the phase results and view options:

**Monitoring Status**

Master (172.27.101.70): connected

Slave 1 (172.27.101.71): connected

Slave 2 (172.27.101.72): connected

**Phase Result**

Show Good Results only

Show Not Good Results only

Show Others Results only

**View Options**

Show Results

Image Contrast Enhancement



## CONFIGURATION USING DL.CODE

For a complete installation including additional configuration parameters such as image saving or Fieldbus communication setup, you must use the DL.CODE configuration software.



**DL.CODE does not currently support Windows Embedded (often used in industrial PCs and/or PLCs).**

To install and run DL.CODE you should have a Laptop or PC that meets or exceeds the following:

- 2.00 GHz or faster microprocessor
- Windows: 7, 8.1, or 10
- 1 GB RAM
- 2 GB hard disk for 64-bit machines; 1 GB hard disk for 32-bit machines
- 100 Base-T Ethernet
- One 19" or larger monitor (optimized for 1280x1024 resolution)

## Quick Start

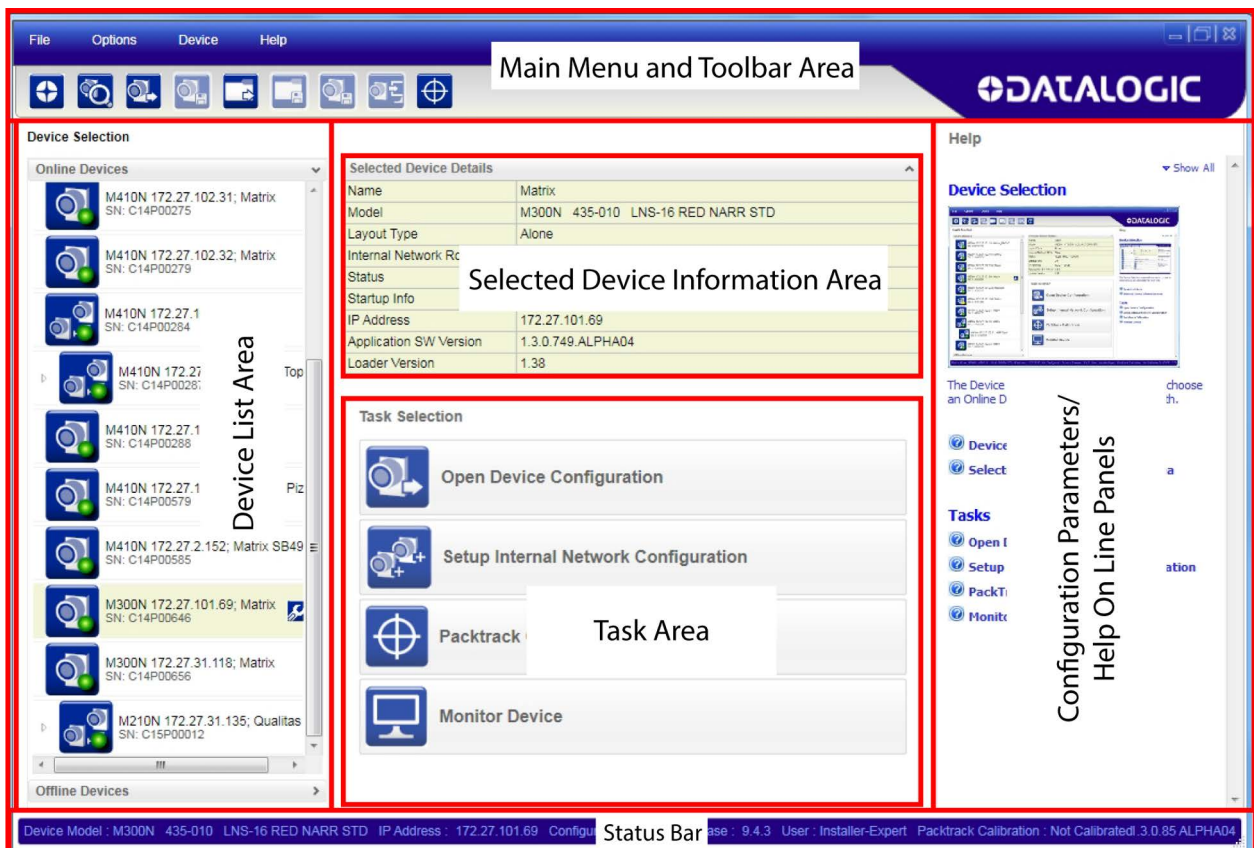

Figure 20 - Main window areas

To help you get started, here is an example configuration demonstrating the basic steps of DL.CODE configuration. To configure your device for your application, the following preliminary steps are assumed:

- The reading device(s) are installed and running.
- DL.CODE is installed and running.

## Ethernet Device Discovery

The User Interface opens and displays a list of all the devices belonging to the Local Area Network. STS320 has a discovery feature to accomplish this task.

The discovery feature will also show devices not belonging to the LAN and display them in gray.

The following procedure will demonstrate an example configuration.

1. First, the device must be added to the LAN by aligning its IP Address to the network. The network administrator should provide valid LAN address(es).
2. Click on the device wrench icon to open the Device Environment Configuration window.
3. Change the Ethernet Settings (IP Address, Subnet Mask, Gateway Address etc.) according to the network requirements.
4. Click OK; the device will reappear in the list of Online Devices (in color) meaning it is now part of the LAN and can be configured. The new IP address will also be displayed.
5. Double-click on or drag the device icon into the Selected Device Information Area. Details about the device will be displayed in this area.



### NOTE

**For Image Saving applications or to take full advantage of the Mosaic feature, you will need to connect the Slave readers to the network, one at a time, and assign IP Addresses to them.**



### NOTE

**After device discovery, you are ready to configure your device through DL.CODE.**

## Device Configuration



### NOTE

**Especially for lengthy configurations, it is always good practice to periodically save the configuration to permanent memory (Save on Device) to avoid losing the configuration in Temporary Memory. You must give a name to the new configuration or overwrite an existing one (except for Default which cannot be modified).**

When all the configuration parameters are set correctly and saved to the device, you can perform a Backup to File and/or to an External storage device (i.e. BM100 present inside the CBX500). See "Backup and Restore Through DL.CODE" on page 49.

DL.CODE is designed to simplify standard configuration by grouping the basic functions into three major parameter groups: Decoding, Operating Mode, and Output.

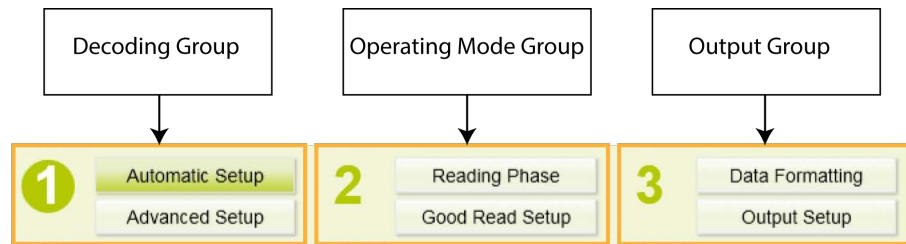

### 1. Decoding

This is preset for Tires applications. Under **Advanced Setup** some parameters can be modified, e.g. code symbologies, or gain and exposure time for applications other than Tires.

### 2. Operating Mode

- **Reading Phase:** this group manages the operating mode for image acquisition (default: Phase mode). A Fieldbus communication channel can be selected under this section.
- **Good Read Setup:** this group manages data collection (default: Code Combination).

### 3. Output

- **Data Formatting:** this group manages the output message to the Host. The Image Saving function can be enabled and managed under this section.
- **Output Setup:** this group manages the digital outputs as well as the Green/Red Spots and 360° Feedback. Control from Fieldbus Master can also be managed under this section.

## Backup and Restore Through DL.CODE

DL.CODE allows Backup and Restore to be performed to/from the configuration PC via file and to the BM100 external storage device inside the CBX500 (both are recommended).

DL.CODE provides complete backup and restore functions (Configuration and Environmental parameters):

For Master Readers in ID-NET Master/Slave networks:

- Backup and Restore functions provide parameter storage of only the Startup Configuration for the Master and all Slaves present in the network.



**For Master/Slave networks any other configurations (jobs) stored in the device memory will not be backed up. Therefore, all jobs other than the startup configuration will be overwritten (erased) upon a restore. It is strongly recommended to save all configurations to backup files.**



**Before executing a Backup to a BM100 backup module make sure the Write Protection switch is set to Unlocked.**

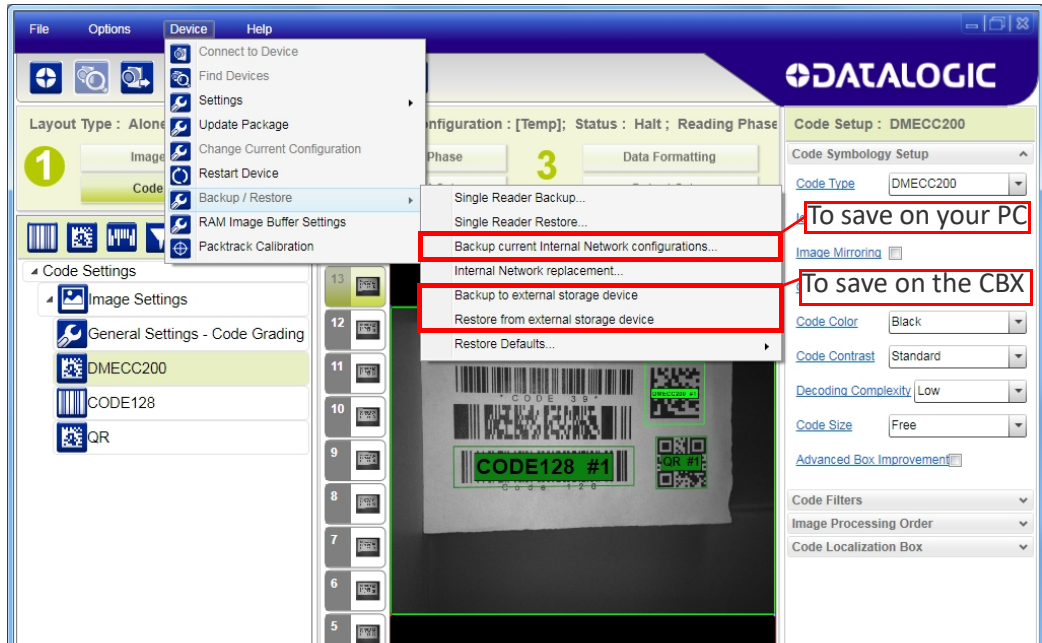

### Backup

To perform a **Backup**, from the DL.CODE Device menu, select **Backup to external storage device** and follow the procedure; then perform a backup selecting **Backup current Internal Network configurations** (to a file on PC) and follow the procedure.

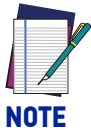

**After executing the Backup to the BM100 module, make sure to lock the Write Protection switch.**

After performing the Backup installation is completed. You can check the station performance using the DL.CODE Monitor or the Web Monitor.

### Restore

To perform a **Restore**, from the DL.CODE Device menu, select **Restore from external storage device** and follow the procedure; then perform a backup selecting **Internal Network replacement** (from a file on PC) and follow the procedure.

### Replacement



**The replacement device must be the exact same model as the device it is replacing.**

The **Restore** function also provides easy and secure Single Device Replacement:

1. Remove the device to be replaced by loosening the screws on the fast bracket, mounting the fast bracket on the new device, and fixing it to the array mounting bracket making sure it is aligned (screws fully seated into the end of the fast bracket slots).

2. Connect the new device (make sure the new device has been previously set to factory default).
3. Run the Restore procedure by selecting **Restore from external storage device** item (see Restore procedure above).

**NOTE**

**In case of Backup or Restore operation failures, error messages will be displayed in the Monitor Diagnostic page.**

## Unreadable Codes Management

Unreadable codes are codes that cannot be completely decoded for some reason (e.g. ruined codes, absent quiet zone, out of image, invalid pattern, etc.). This parameter can be enabled on DL.CODE **Advanced Setup > General Settings**. It is only available for Code 39, Code 128, and Interleaved 2 of 5 symbologies, and only one unreadable code per frame can be detected.

When this function is disabled, any unreadable code will be treated as No Read.

Advanced Setup : General Settings - Code Grading	
<a href="#">Processing Timeout Type</a>	Global
<a href="#">Processing Timeout Value (ms)</a>	500
<a href="#">Processing Mode</a>	Standard - Code Grading
<a href="#">1D CQ Standard</a>	None
<a href="#">2D CQ Standard</a>	None
<a href="#">HW Acceleration</a>	Disabled
<a href="#">Unreadable Codes</a>	<input checked="" type="checkbox"/>

When Unreadable code are enabled, Partial Read events are treated as No Read by default under **Good Read Setup > Code Combination**. If enabled, the Partial Read Message 3 can be associated with this event under Data Formatting.

The screenshot shows the Datalogic software interface. At the top, there are menu options: File, Options, Device, Help. The main window displays configuration settings for a device. On the right side, under 'Good Read Setup : Code Combination', there are three dropdown menus: 'No Read' (Enabled), 'Partial Read' (Enabled), and 'Multiple Read' (Disabled). The 'Partial Read' dropdown is highlighted with a red box. In the center, under 'Code Combination - (DMECC200)', there is a section for 'Expected Code1' showing a barcode icon and 'DMECC200'. Below this, under 'Output Data Channels', there are three message boxes: 'Message1 Good Read', 'Message2 No Read', and 'Message3 Partial Read'. The 'Message3 Partial Read' box is highlighted with a red box. On the right side of the 'Output Data Channels' section, there are three server options: 'Reader TCP Server', 'Main', and 'Aux'. Arrows point from the message boxes to the 'Reader TCP Server' option.

Under **Data Formatting**, Message 3 is associated to the Partial Read event. Here an Expected Code must be added specifying the Local Unreadable Code field, which defines the character or string representing the local unreadable code message (when multiple codes are expected, the Local Unreadable Code string is used to distinguish which code was recognized but not read).

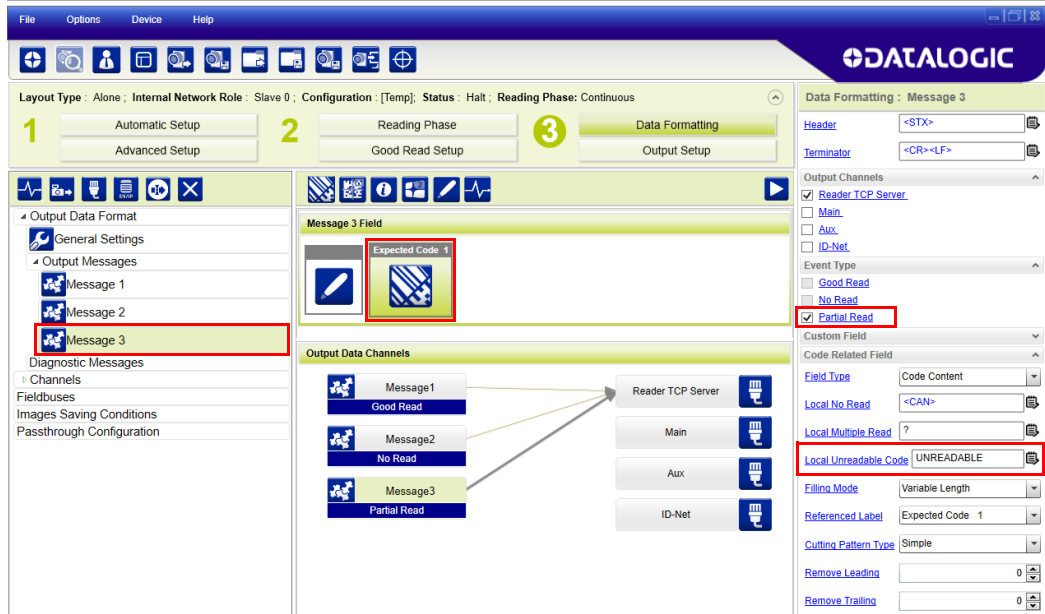

Then an Image Saving condition must be added. Here select which event(s) will determine Image Saving. It is possible to select multiple events so that any one of them will produce Image Saving. Each row identifies the result of the analysis (rows change according to the selected data collection method). Each column represents the result of a single image (Codes found, Unreadable codes found, No Codes found). Pressing the “Reset Selection” button unticks all boxes. Pressing the “Smart Selection” button ticks all relevant boxes according to the options selected in the previous steps.

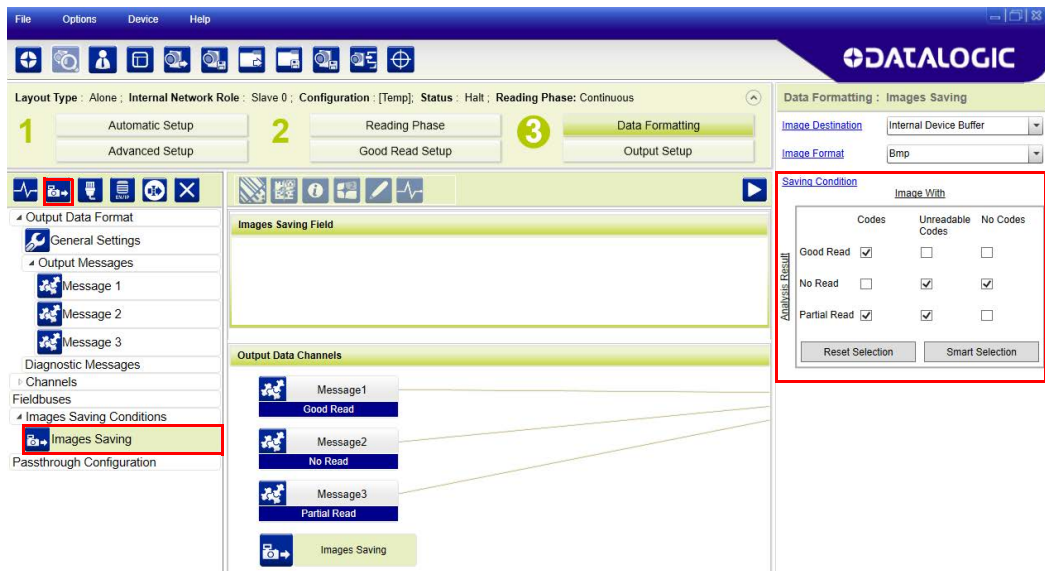

In the example above, Unreadable Codes are saved when the analysis result is either a No Read or a Partial Read.



**NOTE**

**DL.CODE Statistics classifies Unreadable Codes as Partial Reads.**

# CHAPTER 6

## MAINTENANCE

---

### STS320: WHAT YOU CAN AND CANNOT DO

The STS320 comes pre-assembled, configured, calibrated, and tested. Very few changes may be needed (and are allowed) to adapt the system to the plant operating conditions.



#### NOTE

**Several changes are not permitted and if they are carried out the warranty is automatically void.**

- If necessary, the readers' configuration can be altered, but this should be done **only according to the indications in "Software Configuration"** starting on page 40.
- The Matrix 320™ ATS readers are self-contained units (unique part number) and must not be disassembled. In the event of a faulty unit, this must be replaced with another Matrix 320™ ATS.
- The Matrix 320™ ATS lens cover must not be unscrewed or removed. A warranty seal is present that voids warranty if broken.
- The Matrix 320™ ATS lens must not be tampered with to alter the focus/diaphragm adjustment.
- The Matrix 320™ ATS internal illuminator must not be unscrewed or removed.

### CLEANING

Clean the reading windows periodically for continued correct operation of the array (see [General View, starting on page x](#)).

Dust, dirt, etc. on the window may alter the reading performance.

Repeat the operation frequently in particularly dirty environments.

Use soft material and alcohol to clean the window and avoid any abrasive substances.

# CHAPTER 7

## TROUBLESHOOTING

### GENERAL GUIDELINES

- When wiring the device, pay careful attention to the signal name (acronym) on the CBX500 spring clamp connectors (see "Electrical Connections" on page 30).
- If you need information about a certain reader parameter you can refer to the DL.CODE Help On Line.
- If you are unable to fix the problem and you are going to contact your local Datalogic office or Datalogic Partner or ARC, we suggest providing (if possible): Application Program version, Parameter configuration file, Serial Number and Order Number of your reader.

Troubleshooting Guide for STS320 Solutions	
Problem	Suggestion
<p><b>Presence Sensor:</b> the sensor (light barrier) is not working correctly.</p>	<ul style="list-style-type: none"> <li>▪ Check the LEDs on the presence sensor. If the sensor has power, a green LED must be lit. If the sensor has a free path (view) to the reflector, only this green LED should be lit. If a yellow LED is lit together with the green one, please check the mechanical position and orientation of the sensor and reflector.</li> <li>▪ Every time the yellow LED on the sensor is lit, the corresponding LED in the CBX500 ATS connection box must be lit. For Trigger this must be the yellow LED and for the Input 2 the green one. If this is not the case, please check the wiring of the sensors.</li> </ul>
<p><b>No Presence Sensor:</b> No trigger signal from te PLC (if no sensor is used)</p>	<ul style="list-style-type: none"> <li>▪ If a signal from the PLC is correct in the CBX500 ATS connection box, a yellow LED (Trigger) must be lit inside of this box. If this is not the case, please check the wiring and the output of the PLC.</li> </ul>
<p><b>No Trigger Signal at Reader:</b> Is this trigger signal correctly recognized by the reader?</p>	<ul style="list-style-type: none"> <li>▪ If a reading signal (trigger signal) is present and active from the sensor or PLC and the LEDs in the CBX500 ATS connection box are working correctly, the trigger signal LED on the reader must also be lit. As long as this LED is lit, the readers try to read a code. If this LED does not light up, please replace the reader and send it to repair.</li> </ul>



Troubleshooting Guide for STS320 Solutions	
Problem	Suggestion
Does the internal lighting system work correctly?	<ul style="list-style-type: none"><li>▪ If a trigger signal is active and no code is present under the system, all readers must flash blue. If this is not the case, please replace the reader and send it to repair.</li></ul>
Do the readers read codes?	<ul style="list-style-type: none"><li>▪ Place a correctly positioned code under each reader. If the reader has read the code, the GOOD read (green) LED must light up. A green spot must also light up on the code surface. If this is not the case, please replace the reader and send it to repair.</li></ul>

# CHAPTER 8

## TECHNICAL FEATURES

ELECTRICAL FEATURES	
<b>Power</b>	
Supply Voltage	24 Vdc ± 10%
Peak Supply Current	STS320-xx3: 3.1 A STS320-xx4: 4.1 A STS320-xx5: 5.1 A STS320-xx6: 6.0 A Matrix 320 ATS-xxx: 1 A max.
Average Supply Current	STS320-0x3 / -2x3: 1.5 A STS320-0x4 / -2x4: 1.9 A STS320-0x5 / -2x5: 2.3 A STS320-0x6: 2.7 A STS320-1x3: 2.1 A STS320-1x4: 2.7 A STS320-1x5: 3.3 A STS320-1x6: 3.9 A Matrix 320 ATS-0xx /-2xx: 0.42 A Matrix 320 ATS-1xx: 0.62 A
<b>Communication Interfaces</b>	
Embedded	<ul style="list-style-type: none"> <li>Ethernet 10/100/1000 Mbit/s: TCP/IP, UDP, FTP and Fieldbus PROFINET IO, Ethernet IP, Modbus TCP</li> <li>Serial RS232/RS422FD up to 115.2 Kbit/s + Serial Aux RS232 up to 115.2 Kbit/s</li> <li>OPC UA</li> </ul>
Reader Networking	Datalogic ID-NET™
Connectivity Modes	Pass Through, Master/Slave, Ethernet point to point
<b>Inputs and Outputs</b>	
Digital Inputs	2 inputs (opto-coupled and polarity insensitive) Max. Voltage 30 Vdc Max. Input Current 10 mA

## ELECTRICAL FEATURES

Digital Outputs <sup>a</sup>	<p>3 outputs: configurable NPN, PNP, or PP short circuit protected</p> <p><math>V_{OUT}</math> (<math>I_{LOAD} = 0</math> mA) Max. 24 Vdc</p> <p><math>V_{OUT}</math> (<math>I_{LOAD} = 100</math> mA) Max. 3 Vdc</p> <p><math>I_{LOAD}</math> Max. 100 mA</p>
------------------------------	--

- a. When connected to the CBX connection boxes the electrical features for Output 1 and 2 become the following:  
 Opto-isolated;  $V_{CE} = 30$  Vdc max.;  $I_{CE} = 40$  mA continuous max.; 130 mA pulsed max.;  
 $V_{CE\ saturation} = 1$  Vdc max. @ 10 mA;  $P_D = 90$  mW Max. @ 50 °C ambient temp.

## OPTICAL FEATURES

Sensor Type	Image resolution 2.0 Mpixel (1920 x 1080) 16:9 form factor - 1/3" CMOS global shutter
Frame Rate	40 to 60 frames/s depending on application
Pitch	$\pm 35^\circ$
Tilt	$0^\circ - 360^\circ$
Illumination	Internal illuminators with blue lights Internal illuminators power: High Power 14 LEDs, Very High Power 36 LEDs

## ENVIRONMENTAL FEATURES

Operating Temperature <sup>a</sup>	-10 to 50 °C (14 to 122 °F)
Storage Temperature	-20 to 70 °C (-4 to 158 °F)
Max. Humidity	90% non condensing
Protection Class <sup>b</sup> EN 60529	IP65 and IP67
Sulfur Gas Resistance	Available for all models according to ISO EN 60068-2-43

- a. high ambient temperature applications should use metal mounting bracket and the heat sink provided in the package for heat dissipation.  
 b. when correctly connected to IP67 cables with seals and the Lens Cover is correctly mounted.

DECODING CAPABILITY	
Readable Symbologies	<p><b>1D Codes:</b> all standard 1 dimensional symbologies</p> <p><b>2D Codes:</b> Data Matrix, QR Code, Micro QR, MAXICODE, Aztec, Dot code</p> <p><b>Postal Codes:</b> Australia Post, Royal Mail, Kix code, Japan Post, PLANET, POSTNET (+BB), Intelligent Mail, Swedish Post and many more</p>
Code Quality Metrics	<p>1D CQ Standard: ISO/IEC 15416</p> <p>2D CQ Standard: ISO/IEC 16022/18004, ISO/IEC 29158 (AIM-DPM), ISO/IEC 15415</p>

USER INTERFACE AND PROGRAMMING	
Aiming System	Laser cross red projection aiming
User Interface	<ul style="list-style-type: none"> <li>• Configurable 360 degree multicolor visual feedback</li> <li>• Green spot and Red spot LEDs</li> <li>• X-PRESS™ Human Machine Interface</li> <li>• Beeper</li> <li>• X-PRESS™ Push Button</li> <li>• 7 LEDs (Status, Communication, Trigger, Good Read, Ready, Power on, Network)</li> <li>• Web Monitoring and Web Supervisory Interface</li> </ul>
Device Programming	<p>DL.CODE™ Windows-based software (programming via Ethernet or Serial Interface) with Javascript output formatter</p> <p>Serial Host Mode programming</p> <p>X-PRESS™ Human Machine Interface</p>

PHYSICAL FEATURES		
Dimensions	<p><b>STS320-003, STS320-013, STS320-014, STS320-203</b></p> <p>695 x 177 x 119.1 mm [27.36 x 6.97 x 4.69 in]</p>	
	<p><b>STS320-113</b></p> <p>695 x 181.5 x 133.9 mm [27.36 x 7.15 x 5.27 in]</p>	
	<p><b>STS320-103, STS320-114</b></p> <p>726 x 181.5 x 133.9 mm [28.58 x 7.15 x 5.27 in]</p>	
	<p><b>STS320-204</b></p> <p>815 x 177 x 119.5 mm [32.09 x 6.97 x 4.64 in]</p>	
	<p><b>STS320-004, STS320-015, STS320-016, STS320-205</b></p> <p>1095 x 177 x 119.1 mm [43.11 x 6.97 x 4.69 in]</p>	
	<p><b>STS320-104, STS320-115</b></p> <p>1095 x 181.5 x 133.9 mm [43.11 x 7.15 x 5.27 in]</p>	
	<p><b>STS320-116</b></p> <p>1126 x 181.5 x 133.9 mm [44.33 x 7.15 x 5.27 in]</p>	

## PHYSICAL FEATURES

<b>Weight</b>	<b>STS320-003, STS320-013, 5TS320-203:</b> 4.84 Kg (10.67 lbs)
	<b>STS320-103, STS320-113:</b> 5.68 Kg (12.52 lbs)
	<b>STS320-014:</b> 5.54 Kg (12.21 lbs)
	<b>STS320-114:</b> 6.68 Kg (14.73 lbs)
	<b>STS320-204:</b> 6.16 Kg (13.58 lbs)
	<b>STS320-004:</b> 7.44 Kg (16.40 lbs)
	<b>STS320-104:</b> 8.58 kg (18.92 lbs)
	<b>STS320-015, STS320-205:</b> 8.12 Kg (17.90 lbs)
	<b>STS320-115:</b> 9.55 Kg (21.04 lbs)
	<b>STS320-016:</b> 8.80 Kg (19.40 lbs)
<b>STS320-116:</b> 10.51 Kg (23.17 lbs)	
<b>Case Material</b>	Aluminum case and plastic protective window cover

© 2021-2023 Datalogic S.p.A. and /or its affiliates • All rights reserved • Without limiting the rights under copyright, no part of this documentation may be reproduced, stored in or introduced into a retrieval system, or transmitted in any form or by any means, or for any purpose, without the express written permission of Datalogic S.p.A. and/or its affiliates • Datalogic and the Datalogic logo are registered trademarks of Datalogic S.p.A. in many countries, including the U.S. and the E.U.



**Datalogic S.r.l.**

Via S. Vitalino, 13 | 40012 Calderara di Reno | Bologna - Italy  
Tel. +39 051 3147011 | Fax +39 051 3147205